

**ECONOMIC AND PRIVATE SECTOR  
PROFESSIONAL EVIDENCE AND APPLIED KNOWLEDGE SERVICES**

TOPIC GUIDE

# Education economics

A guide through the subject

Joseph Holden

Nathan Associates

Monazza Aslam

Oxford University

May 2014

EPS-PEAKS is a consortium of organisations that provides Economics and Private Sector Professional Evidence and Applied Knowledge Services to DFID. The core services include:

- 1) Helpdesk
- 2) Document library
- 3) Information on training and e-learning opportunities
- 4) Topic guides
- 5) Structured professional development sessions
- 6) E-Bulletin

To find out more or access EPS-PEAKS services or feedback on this or other output, visit the EPS-PEAKS community on <http://partnerplatform.org/eps-peaks> or contact Alberto Lemma, Knowledge Manager, EPS-PEAKS core services at [A.Lemma@odi.org.uk](mailto:A.Lemma@odi.org.uk)

**Disclaimer:**

The views presented in this paper are those of the authors and do not necessarily represent the views of Consortium partner organisations, DFID or the UK government. The authors take full responsibility for any errors or omissions contained in this report.

# Contents

<b>Abbreviations</b>	<b>iii</b>
<b>1 Introduction/overview</b>	<b>1</b>
1.1 Education, learning and the starting point for education economics	1
1.2 The rationale for intervention in education	1
1.3 Structure of this Topic Guide	3
<b>2 Education, skills and growth</b>	<b>4</b>
2.1 Education and economic growth: a short history	4
2.2 Education and growth: a mixed picture from the empirical evidence	5
2.3 Education and inequality	7
2.4 Education, skills and labour markets	8
<b>3 The returns to education</b>	<b>10</b>
3.1 The fundamentals or economic returns to education	10
3.2 Economic returns to education: quantifying the returns	11
3.3 The non-financial (non-pecuniary) returns to education	14
3.4 Education and spillovers	16
3.5 Parental choice: the importance of perceived returns	17
<b>4 Education systems in developing nations</b>	<b>18</b>
4.1 Universal education in developing countries: a very brief history	18
4.2 Education today: an overview	19
4.3 Education today: new evidence from basic skills tests	21
4.4 Education systems: high teacher absenteeism, low teacher effort	22
4.5 Education systems: public private divide	23
<b>5 Education policy, interventions, evidence</b>	<b>26</b>
5.1 How economists assess education policy and interventions	26
5.2 Interventions in education	27
5.3 Supply-side interventions: school materials	29
5.4 Supply-side interventions: improving teachers	30
5.5 Supply-side interventions: school organisation	32
5.6 Demand-side interventions: the ‘nudge’	34
5.7 Demand-side interventions: private vs. public	35
<b>6 Aid, finance and education</b>	<b>38</b>
6.1 Multiple players in education in developing countries	38
6.2 Financing for education, where does it come from?	39
6.3 Fungibility of aid in education	42
6.4 Political economy of aid and education	43
6.5 Value for money of interventions in education	45
<b>References</b>	<b>48</b>
<b>Annex A: Additional data</b>	<b>63</b>
<b>Annex B: Methodological appendix</b>	<b>69</b>

# Abbreviations

ASER	Annual Status of Education Report
CCPC	Chicago Child Parent Center
CCT	Conditional Cash Transfer
CRS	Creditor Reporting System
DAC	Development Assistance Committee
DFID	UK Department for International Development
EFA	Education For All
EPS-PEAKS	Economics and Private Sector Professional Evidence and Applied Knowledge Services
GBS	General Budget Support
GDP	Gross Domestic Product
GER	Gross Enrolment Rate
HIPC	Heavily Indebted Poor Country
ICT	Information and Communication Technology
IMF	International Monetary Fund
IPA	Innovations for Poverty Action
LCT	Labelled Cash Transfer
LLECE	Latin American Laboratory for Assessment of the Quality of Education
MDG	Millennium Development Goal
MDRI	Multilateral Debt Relief Initiative
NGO	Non-Governmental Organisation
ODA	Official Development Assistance
OECD	Organisation for Economic Co-operation and Development
OLPC	One Laptop Per Child
OLS	Ordinary Least Squares
PASEC	Programme for the Analysis of Education Systems
PETS	Public Expenditure Tracking Survey
PIAAC	Programme for the International Assessment of Adult Competencies
PIRLS	Progress in International Reading Literacy Study
PISA	Programme for International Student Assessment
PPP	Purchasing Power Parity
PRP	Performance-Related Pay
PRSP	Poverty Reduction Strategy Paper
R&D	Research and Development
RCT	Randomised Control Trial
RD	Regression Discontinuity
REPOA	Research on Poverty Alleviation
SACMEQ	Southern and Eastern Africa Consortium for Monitoring Educational Quality
SSA	Sub-Saharan Africa
STAR	Student/Teacher Achievement Ratio
TFP	Total Factor Productivity
TIMSS	Trends in International Mathematics and Science Study

TVET	Technical and Vocational Education and Training
UCT	Unconditional Cash Transfer
UK	United Kingdom
UIS	UNESCO Institute for Statistics
UN	United Nations
UNESCO	UN Educational Scientific and Cultural Organisation
UPE	Universal Primary Education
US	United States
VfM	Value for Money
WDI	World Development Indicators
WEO	World Economic Outlook
WHO	World Health Organisation

# 1 Introduction/overview

## Key messages

- **Education economics starts from the basis that there are *returns to education* that increase the wealth and well-being of the educated.**
- **Economists view education as a *merit good*, in that there are externalities or spillovers, meaning returns to education benefit others beyond the person being educated.**
- **Government/public sector intervention in education can be justified by these spillovers, as well as by market failures in capital markets and/or in the provision of information, which mean the market alone would provide insufficient education.**
- **In addition, there is a view of education as a 'right', which means it should be provided regardless of cost–benefit ratios.**

## 1.1 Education, learning and the starting point for education economics

The importance of education in promoting and sustaining both individual and national development is well known. Not only is education considered a basic human right, but also it is acknowledged as influencing a variety of individual, social and life outcomes, whether through greater economic opportunities, better health, the ability to participate more fully in society or greater well-being and happiness. As an indication of its prominence, it forms one-third of the UN Human Development Index calculation.

The central insight leading to the field of education economics is that learning through education leads to the acquisition of knowledge and skills that have economic value. Greater knowledge and skills enable society as a whole to find ways to produce and use goods and services more efficiently and to tackle increasingly complex problems and needs. This leads to higher *returns* that accrue to the individual, his/her family and the wider community. Economists attempt to measure these returns, and in addition seek to understand how to make improvements in education systems, to reduce the large educational inequalities seen worldwide.

## 1.2 The rationale for intervention in education

Education is not a public good in the economist's sense of being *non-excludable* and *non-rivalrous*. On the contrary, it is both excludable (a child can be refused entry to school) and rivalrous (schools have limited capacity). Instead, then, it can be considered a *merit good*, which means it is something that has positive spillovers or externalities associated with its acquisition. This provides the basis for the idea that government interventions in education can be justified. Spillovers are the first of a number of justifications for intervention based on the presence of *market failures* in education.<sup>1</sup>

### The market failures argument: spillovers/externalities

Spillovers or externalities occur in education when the person being educated is not the only person to benefit from it. While benefits to the individual being educated may be substantial in terms of increased future earnings and in other respects (see Chapter 3), an individual's education also delivers significant advantages to other people. These

---

<sup>1</sup> Economies of scale are generally not seen as one of the market failures, although there is some evidence for them, with it being cheaper to educate more children in larger schools (see Lewis and Chakraborty, 1996).

benefits may include the following: more educated people allowing an economy to operate with greater productivity, hence raising wages for the whole community (see Chapter 2 on education and growth); improvements in the health of the children of the educated (see 3.4); or reductions in crime (see 3.3) and so forth. However, positive spillovers are not likely to be taken into account in the individual's decision to be educated. This means the *social return* to an individual's education may be greater than the *private rate of return*. Public policy is therefore justified in trying to ensure achievement of the optimal level of education to *maximise* society's welfare.

### The market failures argument: capital market failures

The benefits from education are achieved far into the future, but the costs of acquiring this education are incurred in the shorter term. This introduces an element of uncertainty into what the returns will be. Moreover, those who invest in a child's education, usually the parents, may not necessarily be the ones who benefit from the returns: a person with a higher wage as a result of their education may not give anything back to their parents who paid for it.<sup>2</sup> This means the main driver behind a parent putting their child in school may be altruistic, and/or may be shaped by strong cultural dimensions. The desire to conform to societal norms or make the right 'investment' decisions may be more important in the short term than long-term calculations about uncertain returns.

Even if the returns to education are large and positive, the size of the investment may be larger than a parent can afford. With perfect capital markets, a parent could borrow to fund the investment. However, given the absence of collateral, for scale and information reasons, capital markets often do not work well for the poor (see Stiglitz and Weiss, 1981). This provides another rationale for intervention in education by the government.

### The market failures argument: information failures

Another natural consequence of the length of time taken to educate a child is that the scale of returns is very uncertain. As Chapter 3 shows, economists struggle to calculate what the social or private returns to education are, and may even be divided in opinion as to whether it is years of education or the qualification received that leads to returns. Parents may find it even harder to estimate the private returns, and face a number of information failures. Parents' *perceived returns to education* (see 3.5) therefore matter greatly to their investment in their children's education; inasmuch as there is evidence that perceived returns are lower than actual returns, this provides another justification for intervention in education.

### Education as a right

The rights-based approach places education alongside other human rights, such as to freedom from torture or from arbitrary arrest, or freedoms of thought and expression. The right to education is enshrined in Article 26 of the UN Declaration of Human Rights: 'Education shall be free, at least in the elementary and fundamental stages. Elementary education shall be compulsory.'<sup>3</sup>

While the rights-based approach provides people from all countries with an internationally recognised legal basis for access to education, the underdevelopment of legal systems and poor awareness of human rights mean this may not be effective. However, it can be argued that it has done the most to raise education up the global agenda to the point that education is central to two out of the eight UN Millennium

<sup>2</sup> In some developing countries, for example, societal norms dictate that any income married women earn not be spent on their parents. However, the very parents who do not reap the subsequent benefits made the educational investment; this would apparently be a substantial disincentive for them to invest.

<sup>3</sup> <http://www.un.org/en/documents/udhr/>

Development Goals (MDGs).<sup>4</sup> Despite this, even primary education has not become truly universal for many. Figure 1 shows there are 14 countries with more than 1 million children of primary school age who are out of school.

### 1.3 Structure of this Topic Guide

This Topic Guide seeks to provide an introduction to the main questions and controversies in education economics, especially with respect to developing countries.<sup>5</sup>

Chapter 2 describes links between education, skills and growth, including how the main theories of economic growth have understood education; results and controversies in the empirical literature on education and growth; and education and inequality, labour markets and migration.

Chapter 3 provides an overview on *returns to education*, the key microeconomic concept in education economics, and includes estimates of both economic returns and other returns, such as to health, political participation and reduced crime.

Chapter 4 provides an introduction to the education systems of developing countries, covering the quantity and quality of education undertaken, international comparisons of student assessments, evidence on teacher absenteeism and the key features of public and private education in developing countries.

Chapter 5 summarises the evidence for interventions and policies in education, drawing on international evidence on *what works* for increasing both quantity and quality, including a wide array of supply- and demand-side interventions.

Finally, Chapter 6 looks at how education in developing countries is funded, the role of international aid, how aid money is spent and the political economy of aid and education and finally what evidence means for informing the likely value for money (VfM) of education interventions.

**Figure 1: Fourteen countries with more than 1 million primary children out-of-school**



Note: Countries in bold, no official data, estimates inferred by UNESCO. Source: UNESCO (2014).

<sup>4</sup> <http://www.un.org/millenniumgoals/>

<sup>5</sup> As a topic guide for the UK Department for International Development (DFID), this study focuses most on education in developing countries, but does also draw on evidence from developed countries, which often have a richer set of empirical literature on key relationships of interest. As Annex B sets out, most economic methodologies for determining relationships and causality are data hungry; in particular, they often require long-running panel data studies – which are generally available only for developed countries at this point in time. The guide also focuses more on schools at primary and secondary education levels, with less on tertiary education, adult education and technical and vocational education and training (TVET).



## 2 Education, skills and growth

### Key messages

- Education enters growth theory in the guise of 'human capital', a greater amount of which makes an economy more productive.
- Neoclassical growth theory sees human capital as an input into production, with technology *exogenously* determined. More investment in education and thus human capital will raise growth proportionately to this investment but with *diminishing returns*.
- Endogenous growth theory makes human capital more fundamental, as an input to production and growth, and as an input to advancing technology as well as the ability to absorb existing technologies. This means technology is *endogenously* determined, and investment in human capital can have *constant* or even *increasing returns*.
- The empirical literature tends to use cross-country regressions to assess the importance of education in driving growth. This evidence is mixed and faces methodological issues about whether proxies measure *quantity* or the *quality* of education, with the latter appearing to be more strongly related to economic growth.
- Differences in education are also linked to greater inequality within countries, with educational inequalities reducing income mobility between generations, exacerbating inequalities in wealth distribution.
- Evidence also suggests it is the types of skills that will link into how much education improves productivity; for example, engineering graduates are more beneficial than law graduates for growth in gross domestic product.
- Where there is a 'brain drain' of highly skilled individuals, the link from education to growth may not hold, although other effects, such as greater remittances from migrants, may offset this.

### 2.1 Education and economic growth: a short history

The growth in a country's national income, its gross domestic product (GDP), implies a country has more goods and services to go around. Higher GDP is associated with lower poverty, and with positive outcomes such as reductions in infant mortality, higher life expectancy and – with less certainty – greater happiness and life satisfaction.<sup>6</sup> In addition, richer countries tend to have more educated populations. The 'elusive quest' for economists has been to find what causes economic growth,<sup>7</sup> and how much education is one of the key drivers behind countries becoming richer over time.

#### Neoclassical growth theory and education as human capital

Education has entered into the theory of economic growth under the guise of *human capital*. Human capital is taken to be a measure of the skills and knowledge of the working-age population. The theory of economic growth developed in the mid-1950s, known as the *neoclassical* or *Solow–Swan model*, used the production function for a firm and applied it to an entire economy. In this model, there are two factors – human capital

<sup>6</sup> For an excellent look at GDP and its key correlations, see <http://filipsagnoli.wordpress.com/stats-on-human-rights/statistics-on-gross-domestic-product-correlations/>

<sup>7</sup> See Easterly (2001) for an accessible summary of the theory and evidence on economic growth.

and physical capital (machines etc.) – with diminishing returns to each, meaning investment in both is required for sustainable growth. Human capital here is a cause of growth, but only up to a point. The theory treats technological change as *exogenous* to the model, as ‘manna from heaven’.<sup>8</sup> If technology is equally available to all countries and there is free movement of capital and labour, the model leads to a prediction that, in the long run, countries should converge towards the same level of income.

### Endogenous growth theory; education as central to technology and productivity

The convergence of rich and poor countries is something that by and large has not occurred (see Figure A1 in Annex A), leading to the *convergence controversy* (see Lucas, 1988; Romer, 1986; 1994), and in part to the emergence of a competing theory of economic growth in the 1980s and 1990s: *endogenous growth theory*.

The apparent divergence between countries could be explained if human capital has a further role, in determining the level of technology a country can operate at.<sup>9</sup> This could be because workers with higher skills are more capable of innovating new technologies, or because higher levels of skills are required to absorb, adopt or adapt existing technologies available from other countries. This means technology becomes *endogenous* in the growth model, that is, determined by investment in human capital and the amount of skills in an economy.<sup>10</sup> Thus, models from endogenous growth theory would predict that investment in education and thus human capital could generate *constant* or even *increasing returns*. This could then explain divergence between countries over time, as richer countries investing in more human capital would also be expanding their ability to be more productive and work at higher levels of technological sophistication.

## 2.2 Education and growth: a mixed picture from the empirical evidence

There is an extensive literature that attempts to determine the extent to which the rate of growth in an economy can be attributed to increases in education. The research typically uses data on a cross-section of countries spanning a period of time that can range from five to twenty years, running regressions to provide estimates that try to explain economic growth. The research can also be seen as a test of the two theories of economic growth, and in particular their predictions as to whether countries should *converge* or *diverge* in affluence over time.

The results of this research have yielded mixed and controversial findings, including the following:

- Barro (1991), using data on 98 countries, found a strong and significant relationship between human capital (proxied by school enrolment rates) and subsequent income growth. He concluded that ‘poor countries tend to catch up with rich countries if the poor countries have high human capital per person’.
- Benhabib and Spiegel (1994) found that, while initial human capital mattered, changes to human capital in the 1960-1985 period did not lead to greater GDP per capita growth, suggesting countries that experienced big increases in education enrolment did not see a benefit in terms of growth.

---

<sup>8</sup> A phrase coined by one of Solow’s British contemporaries, Joan Robinson (1953).

<sup>9</sup> Nelson and Phelps (1966) set out an early model with human capital having this role.

<sup>10</sup> Investments go beyond education and include research and development (R&D) and the ‘learning-by-doing’ of workers. See Romer (1994).

- Sala-i-Martin (1997) ran *4 million regressions* to test which variables would cause growth, finding a strong relationship between primary school enrolment in 1960 and growth, but not secondary enrolment.<sup>11</sup>
- Pritchett (1997) found evidence of ‘divergence, big time’, and that, while rich countries have tended to converge together because of similarities such as having the same technology – known as *conditional* or *club convergence* – poor countries have diverged over time, with only a few notable exceptions. The latter provides some support to the endogenous growth theory.

### **Box 1: Evidence of a positive bias potentially overrating the impact of education on economic growth**

It is important to note that there is a possibility of a positive bias towards the importance of education, given that education is generally perceived as a good and a likely cause of growth (Temple, 2001). An analysis of 56 studies, including 979 estimates on the link between education and growth, by Benos and Zotou (2013) indeed finds there is a significant *upward publication bias* towards a positive impact of education on economic growth. However, they still find a ‘genuine effect of education on economic growth’ when controlling for this publication bias.

### **The direction of causality: from education to growth, or from growth to education?**

The positive bias on the importance of education may manifest itself in the old economist’s flaw of confusing correlation with causation – that is, could it be that higher income causes a country to become more educated rather than the other way around? This could be the case if education itself has elements of a consumption good about it – that is, as people become richer they choose to *purchase* more education for its own sake, beyond its function as an investment. Empirically:

- Bils and Klenow (2000) find that the ‘channel from expected growth to schooling’ is capable of generating more than two-thirds of the relationship between the two, although they note this finding may owe to omitted variables.<sup>12</sup>
- Brückner and Gradstein (2013) use country panel data and oil price shocks as an *instrumental variable* (IV) that should be correlated with growth independently of investment in education. They find via this method that a 1% increase in GDP per capita increases the secondary school enrolment rate by 0.1 to 0.18 percentage points on average.<sup>13</sup>

These studies do not prove conclusively that growth causes education rather than the other way around, but they do point to the likelihood of bidirectional causality.

### **Measuring the quantity or the quality of education?**

Many economists have sought to explain the apparent uncertainty around the education and growth link via measurement and estimation problems. Studies originally tended to use the *number of years of schooling* as their estimate of human capital, even though this implicitly assumes that one year of schooling represents the same *quantity* of human capital across countries. On the contrary, internationally comparable tests show widely ranging levels of measured learning across countries – for example, in

<sup>11</sup> In addition, the effect on growth was weaker than for other variables, such as rule of law, degree of dependence on the mining sector, openness to trade and presence of economic distortions.

<sup>12</sup> They state, ‘A second possibility is that the strong empirical relation between schooling and growth reflects policies and other factors omitted from the analysis that are associated both with high levels of schooling and rapid growth in total factor productivity (TFP) from 1960 to 1990. For example, better enforcement of property rights or greater openness might induce both faster TFP growth and higher school enrolments.’

<sup>13</sup> Toya et al. (2010) use a similar approach, with natural disasters as the instrumental variable; they find that climatic disasters are significantly correlated with several measures of education, again suggesting the causality between growth and schooling is bidirectional.

Programme for International Student Assessment (PISA) mathematics tests, Peruvian 15 year olds enrolled in education score 30% less than their US peers.<sup>14</sup>

Hanushek and Woessmann (2010), using PISA data, find that the skills measures explain much of the difference in the growth performance of OECD countries from 1960 to 2000.<sup>15</sup> Unfortunately, the likes of PISA data are not available for all countries, especially poorer developing countries, with just 65 high- and middle-income countries represented in the most recent 2012 PISA data collection exercise. Hanushek and Woessmann (2012) therefore splice together regional skills data with worldwide assessments. In doing so, they find that over half of Latin America's relatively poor growth rates can also be ascribed to low educational achievement. The majority of sub-Saharan African (SSA) countries do not yet have internationally comparable skills data, although regional data have now been collated in some instances (see 4.3).

## 2.3 Education and inequality

### Education and inequality: educational inequalities exacerbate wealth inequalities

The education and economic growth literature looks at how improving the total *stock* of human capital in an economy can generate more wealth for an entire society. However, this does not address the issue of how human capital is *distributed* across society, and the potential inequalities in the returns to education associated with a particular distribution. Inasmuch as those with more education and higher levels of skills receive higher returns and those with more education tend to transmit this to their children, education itself can exacerbate existing economic inequalities.

#### **Box 2: Evidence from the developed world suggests educational inequalities do drive wealth inequalities, with more private education exacerbating the effect**

There is significant evidence from developed country contexts that educational inequalities have exacerbated low intergenerational mobility over time,<sup>16</sup> and hence inequality has persisted or increased. Blanden (2005) looks at the importance of education in explaining intergenerational mobility in the UK, the US, West Germany and Canada. She finds that differential levels of education explain between 35% and 50% of intergenerational mobility across countries. Again looking at developed countries, Davies et al. (2005) find inequality is lower and mobility is higher in the long run under public education than it is under private education. In countries where private education has played a less important role – such as Canada, Sweden and Finland – intergenerational mobility is higher and inequality lower than in those where it plays a more prominent role – such as the US and the UK.

Unfortunately, scant evidence exists for developing countries. An exception is the work of Asadullah (2012), who examines a unique dataset on parental assets and wealth mobility in 141 villages in rural Bangladesh. He finds that low mobility in educational attainment is the key determinant of limited father–son mobility in wealth. Additionally, schooling is found to be a key source of persistence in wealth across generations of the same family. For example, intergenerational mobility is very low among children of uneducated fathers: almost 60% of them stay uneducated and only 14% manage to

<sup>14</sup> The [Programme for International Student Assessment \(PISA\)](#) is a study run by the Organisation for Economic Co-operation and Development (OECD). PISA (2012).

<sup>15</sup> Breton (2011) claimed to demonstrate that Hanushek and Woessmann's statistical results were 'invalid', because of misspecification of the growth model and because the test score data used were not representative of the overall workforce during the growth period. Re-specifying the model, Breton found that average schooling attainment and test scores both explain growth, therefore finding quantity as well as quality is important.

<sup>16</sup> Intergenerational economic mobility is said to have occurred if children occupy different positions in their generation's distribution of earnings/income than their parents did in their generation's distribution of earnings/income. Analysis of intergenerational mobility requires panel datasets, where a regression is done on child's income (on reaching working age) and parental income; of the form  $\ln Y^{\text{child}} = \alpha + \beta \ln Y^{\text{parents}} + \varepsilon_i$

obtain education beyond primary schooling. These findings of large and persistent wealth inequalities over generations and subsequent *poverty traps* have important implications for the process of economic development. The Bangladeshi evidence clearly suggests that equalising educational opportunities is one of the means by which individuals can break out of deeply persistent poverty traps.

## 2.4 Education, skills and labour markets

### How the institutions and policies of a country may affect the education-growth link

The returns to education that generate economic growth are unlikely to be caused simply by *generic skill sets*, but more by specific skills that the labour market demands. In addition, the ability of an economy to put skills to work in the labour market is likely to be crucial to the impact of human capital on growth. As Easterly (2001) puts it, a government that fixes the exchange rate, prohibits trading of foreign currency and creates high inflation gives opportunities to lobby government to turn a profit. If this non-productive 'rent-seeking' activity is rife, and skills of lobbyists make them more effective, then it is possible that education could perversely lead to less growth.<sup>17</sup> That is, the returns to education are there for individuals but not for society.

This idea is explored further by Rogers (2008): data on corruption, black market premia and brain drain to the US for 53 developing countries are used to divide them into sub-samples. Rogers finds that sub-samples with higher reported corruption, black market premia or brain drain will have a lower impact of schooling on economic growth for the period from 1965 to 1995; 'the lesson is that investment in schooling creates a potentially powerful resource for raising economic growth, but it is possible to waste this resource'. It therefore seems likely that it is what the jobs *are* that matters.

### Migration, the brain drain and growth: the impact of educated workers leaving home

An additional reason education might not always lead to economic growth is outward migration, otherwise known as 'human capital flight' or 'brain drain'. The standard channels from education to growth in the presence of significant outward migration may not hold, as spillovers from investment in education will benefit the economy of another country instead. While this was once seen as a zero-sum game, with the home country losing out and the host country gaining, there is now plenty of evidence of off-setting effects, notably through direct remittances from those working abroad, returnees bringing back greater skills, practices and technologies<sup>18</sup> and migration increasing the incentive to invest in skills within the home country. In addition, by easing credit constraints through remittances, migration of some may help others have a chance to access schooling.

Remittances have significantly increased in both real and absolute terms in recent years. Flows of workers' remittances to developing countries were estimated to have reached \$160 billion in 2004 (Acosta, 2006); in 2007 they were estimated at \$240 billion;<sup>19</sup> in 2011 there were at \$483 billion, with \$351 billion flowing to developing countries – nearly 6% of GDP for low-income countries.<sup>20</sup> Remittances bring other benefits. Cox Edwards and Ureta (2003) and Acosta (2006) provide evidence that remittances increase educational attainment of children in El Salvador, and that they are negatively related to child labour, while additional income derived from migration increases girls' education in

---

<sup>17</sup> In addition, the allocation of talent may matter; for example, Murphy et al. (1991) found a strongly positive impact on growth of engineering graduates, and a negative association between the relative share of law graduates and growth.

<sup>18</sup> See Dustmann et al. (2010) for a model on how return migration can lead to a mitigation of the brain drain, or even the creation of a 'brain gain', where those who return bring the home country augmented local skills.

<sup>19</sup> See <http://content.time.com/time/interactive/0,31813,1737566,00.html>

<sup>20</sup> See <http://www.imf.org/external/pubs/ft/fandd/basics/remitt.htm>

particular. López-Córdova (2005) shows that municipalities in Mexico with more remittances see higher literacy and school attendance rates among 6-14 year olds.<sup>21</sup>

The effect of return migration may be especially strong where the highly skilled do return to their home country. Of the foreign-born population that entered the UK in the 1990s staying for at least one year, about 40% left after five years (Dustmann and Weiss, 2007). However, as noted in Dustmann and Glitz (2011), return migration for the most highly skilled (for example PhDs) is likely to be limited. The stronger effect may be via the incentives provided for investing in education in the home country. Beine et al. (2008) find a positive effect of skilled migration prospects on human capital levels in a cross-section of 127 developing countries. Countries combining relatively low levels of human capital and low-skilled emigration rates are more likely to experience a beneficial brain drain (a net positive effect). However, the majority of countries appear to experience a detrimental effect, particularly small developing countries.

**Box 3: The opportunity of migrating to richer countries may change what is studied at tertiary level in developing countries, with a detrimental effect on growth**

Some have posited another channel for the effect of migration on growth – that is, on the types of subjects students choose in tertiary education when outward migration is an option. Di Maria and Lazarova (2009) find that higher rates of skilled migration decrease the share of students in tertiary education studying science and technology in less developed countries. The authors posit that this may be because these skills are the most likely to face obsolescence, and tertiary institutions of developing countries are less likely to be able to train students to the latest levels of science and technology and hence to be competitive internationally. This effect leads to a negative effect for these *home countries* on growth even when controlling for positives such as remittances.

---

<sup>21</sup> Children may suffer from having an absent parent, however. Cortés (2010) provides evidence that children of migrant mothers in the Philippines are approximately 10 percentage points more likely to be lagging behind in school compared with children with migrant fathers.

## 3 The returns to education

### Key messages

- The most common tool in education economics has been the 'Mincerian equation', used to measure the economic return to education by regressing wages on the amount of schooling individuals receive.
- The Mincerian equation has been run for just about every country, with returns to a year of schooling consistently around 10% or more, with higher levels of education generally generating higher returns.
- There are significant methodological difficulties in establishing whether it is years of schooling, the ability of the child and/or the qualification that causes measured returns. Studies that separate out these factors require large and accurate sets of long-term panel data on cohorts, which are generally unavailable for developing countries.
- Non-financial returns to education are also significant, particularly in improving health outcomes, reducing crime and increasing political participation.
- The children of more educated people are also more likely to have better educational and health outcomes.
- Evidence suggests parents may not correctly perceive what returns to education are, and may see only the value to a qualification or level of education rather than the return to each and every year.

### 3.1 The fundamentals or economic returns to education

The previous chapter showed it is likely a country with a more educated population will experience higher economic growth over time. This *macroeconomic* return should have its counterpart in *microeconomic returns*, where educated individuals have higher productivity and earn more than they would have without that education. This chapter looks at efforts to quantify this *economic return to education* for the individual, as well as other *non-pecuniary* (non-financial) *returns* such as to their health or other measures of well-being. In addition, it looks at how *private returns* may be complemented by *social returns* in terms of the spillovers of an educated population to those around them.

#### Estimating the returns to education

As in the macroeconomic theory of economic growth, microeconomic theory expresses the embodiment of education in the idea of *human capital*.<sup>22</sup> Where physical capital has a return in the form of profits to the firm, human capital has its return in the form of earnings/wages to the individual. This is the key premise of *human capital theory*: in competitive markets, a person's wage equates to their productivity (or *marginal product of labour*). Therefore, the difference in a person's productivity owing to education should feed into their earnings, forming their *economic returns to education*.

#### Box 4: The central tool of education economics – the Mincerian wage regression

Jacob Mincer (1974) provided the empirical model that cemented this human capital hypothesis. The so-called Mincerian wage regression involves estimating an empirical relationship by regressing the log of earnings on a number of key variables:

<sup>22</sup> An approach pioneered by Becker (1964).

$$\log y = \log y_0 + rS + \beta_1 X + \beta_2 X^2$$

The dependent variable  $y$  is earnings ( $y_0$  is the level of earnings of an individual with no education and no experience), with explanatory variables including  $S$ , the years (or levels) of schooling completed;  $X$  is years of potential labour market experience, with  $X^2$  indicating the wage increase with work experience but at a decreasing rate (the coefficient  $\beta_2$  being negative). The coefficient  $r$  in such an equation is then interpreted as the *rate of return* to an additional year (or level) of schooling in higher lifetime earnings.

### The signalling theory critique: are returns the result of ability rather than education?

The most influential critique to the standard Mincerian approach comes from *signalling theory*, whereby the return to education comes from the innate ability of the individual rather than skills acquired by education. Qualifications are simply a stamp of approval to *signal* an individual's ability to employers. This is based on the idea that, in a labour market, there is asymmetrical information, in that it is not always possible for the employer to know employees' ability and skills on hiring them (Spence, 1973). As the productivity of the worker is revealed when the individual starts their job, the employer can make the hiring decision based only on observable characteristics such as qualifications. An investment in education can therefore be seen as the individual's *cost of signalling*.

This critique has been well debated in the empirical literature on returns to education. The signalling critique led to the idea that a simple Mincerian equation such as that above would suffer from *omitted variable bias* – in which a missing variable correlated with both education and wages is the true causal factor, and therefore the return to education itself would be over-estimated. According to Spence, this omitted variable would be ability. This has led to second-generation research into rates of return into education to attempt to control for innate ability.

## 3.2 Economic returns to education: quantifying the returns

Using data from the US, Mincer (1974) estimated that an extra year of schooling leads to 11% of extra earnings for the rest of a person's life.<sup>23</sup> Mincer's work inspired a large body of literature, with further estimates of returns to education for over 100 countries. The economist George Psacharopoulos and colleagues (1985, 1994, 2004a) have periodically compiled average Mincerian returns to education.<sup>24</sup> Most recently, Psacharopoulos and Patrinos (2004a) found returns to education are substantial, higher than Mincer's original estimate, and significant across countries with different per capita incomes. On average, returns are slightly larger in low- and middle-income countries than in high-income countries, which is explained partly by the lack of well-educated and skilled people in the former set of countries. This is summarised in Table 1.

<sup>23</sup> Strictly speaking the coefficient on  $S$  is simply the marginal benefit and not the marginal return to schooling since it does not take into account the direct costs of education. Private returns to education are always higher than the social returns if education is publicly subsidised.

<sup>24</sup> Bennell (1996) criticised Psacharopoulos' (1994) estimates, arguing that many of the original studies on which the synthesis drew relied on very poor quality data and utilised methods that were flawed. Banerjee and Duflo (2005) provide the latest compilation of rates of returns, compiled in Psacharopoulos and Patrinos (2004a), and update it, flagging observations that Bennell (1996) rated as being of 'poor' or 'very poor' quality. They find that resulting estimates of Mincerian rates of returns seemed to vary little across countries, with mean rate of returns still at 9%, with a standard deviation of just 2.2%.



**Table 1: Private economic rates of return to education by level and per capita income**

Per capita income group	Primary	Secondary	Higher	
Low income (\$755 or less)	25.8%	19.9%	26%	
Middle income (up to \$9,265)	27.4%	18%	19.3%	
High income (\$9,266 or more)	25.6%	12.2%	12.3%	
World	26.6%	17%	19%	
<i>Source: Psacharopoulos and Patrinos (2004a) estimates.</i>				
Country	Primary	Middle	Secondary	Higher
Ghana (1998)	11%	3.9%	12%	44%
Côte d'Ivoire (1987)	15%	14%	22%	16%
Kenya (1994)	-	11%	7.4%	21%
South Africa (1993)	-	1.4 - 7.3%	20 - 22%	20 - 30%
Nigeria (1999)	1.6%			12.7%
Burkina Faso (1998)	7.9%		10.9%	12.9%
<i>Source: Schultz (2004b) estimates.</i>				

Evidence from Psacharopoulos and Patrinos (2004a) seems to suggest *diminishing returns to schooling*, that is, returns being higher for primary level than for secondary level. However, as evidence cited by Schultz (2004b) shows, returns measured by household surveys for a number of African developing countries seem to be higher at secondary and post-secondary levels than at lower education levels. Colclough et al. (2009) make similar findings from research in South Asian countries,<sup>25</sup> and note that this should not reduce the focus on primary education, since 'primary education is a necessary input into further levels of education which may have higher economic returns. If the benefit that primary education confers by permitting access to more lucrative levels of education is taken into account, its "true" return will increase.'

#### Methodological challenges: controlling for the person's ability

In an echo of the methodological debates in the relationship between education and growth (see Chapter 2), there are debates in the literature as to whether the economic returns to education owe to years of schooling or something else. In particular, earnings differentials between individuals with varying schooling levels could reflect differences in innate/inherent ability, which are typically unobserved by researchers, and which may be correlated with the observed measure of years of schooling. Because of the difficulty in controlling for ability in earnings functions, the estimate of 'returns to schooling' arrived at in empirical regressions could be biased and the key variable – schooling – potentially 'endogenous'. Indeed, once adjustments for family background are made – which could indicate a person's cognitive skills and/or their connections and ability to get ahead in the labour market – returns to schooling are generally reduced.<sup>26</sup>

Various methods have been used in the empirical literature that address the 'endogeneity' of schooling that arises from unobserved 'ability' in earning function estimates. These include the use of 'instrumental variables'; using ability test scores in earnings functions directly; or the use of 'twins' or sibling samples (see Annex B for details on methods used). The broad consensus from the set of studies using different empirical methodologies is that the average of the marginal return to schooling obtained in such studies is typically as big or bigger than conventional estimates from a human

<sup>25</sup> Results they cite include those from Appleton et al. (1999); Aromolaran (2006); Carneiro et al. (2011); Duraisamy (2002); Kingdon (1998); Kingdon and Unni (2001); Lassibille and Tan (2005); Moll (1996); Patrinos et al. (2009); Söderbom et al. (2006); and Vasudeva-Dutta (2004).

<sup>26</sup> See Behrman and Wolfe (1984); Heckman and Hotz (1986); Kingdon (1998); and Lam and Schoeni (1993).

capital earnings function fitted by simple OLS regression.<sup>27</sup> This suggests the returns estimates based on OLS regressions that do not explicitly control for ability bias are not very different from the estimates obtained from the more stringent methodologies. Even after putting earnings functions through a series of empirical and methodological challenges, strong returns to schooling remain.

### Methodological challenges: measuring quality rather than quantity

Similar to the critiques of the growth and education literature seen in Chapter 2, one of the key criticisms of this literature is that conclusions have been drawn based on a reliance on *years of schooling*, a variable that does not account for the *quality* of education received. Many studies have attempted to address this challenge, including measures of both quantity and quality of schooling in earnings function analyses, where quality is usually estimated using standardised test scores. The evidence consistently shows that quality of schooling has at least the same payoffs as the quantity of schooling acquired (Hanushek, 2003).

Hanushek (2005) cites three studies from the US showing quite consistently that a one standard deviation increase in mathematics test performance at the end of high school translates into 12% higher annual earnings. Hanushek also cites three studies from the UK and Canada showing strong productivity returns to both numeracy and literacy skills. Other studies cited indicate substantial returns to cognitive skills in developing countries such as Ghana, Kenya, Tanzania, Morocco, Pakistan and South Africa. A more recent study by Hanushek et al. (2013) exploiting the new OECD Programme for the International Assessment of Adult Competencies (PIAAC) survey of adult skills over the full lifecycle in 22 countries shows that, on average, a one standard deviation increase in numeracy skills is associated with an 18% wage increase among prime-age workers. Hanushek's work has been crucial in showing *quality matters* at least as much as the quantity of education.

### Methodological challenges: Is it the qualification, the years or the types of skills?

An additional critique of the returns literature comes more directly from Spence's signalling theory. This is that it is the qualification that drives returns rather than the years of schooling – so-called 'sheep skin effects'. Dickson and Smith (2011) use a rise in the school leaving age in England and Wales in 1973 to identify returns to years' schooling via a rule that allowed some individuals to leave before gaining qualifications, the so-called Easter Leaving Rule.<sup>28</sup> This natural experiment shows sizeable returns to academic qualifications – increasing the probability of employment by 40 percentage points; and qualifications drive more than 70% of the estimated return to education.

More recently, studies are looking at the returns to particular skills to try to disentangle all the possible reasons for returns to education. These include the following:

- Soares de Baldini Rocha and Ponczek (2011) look at the return to literacy in Brazil. They find a 10% return in additional income for individuals who become literate.
- Godoya et al. (2007) find that Spanish language skills in the Bolivian Amazon region are extremely important, with Spanish speakers earning 37-47% more than monolingual speakers of the local language.
- Aslam et al. (2012) for Pakistan show that basic-order cognitive skills (literacy) promote women's entry into the lucrative wage occupations, and for men higher-order cognitive skills are required for the same benefit. However, they find no direct effect of measured ability in the earnings functions, either for men or for women, and find no evidence of signalling.

<sup>27</sup> See Card (2001). OLS stands for ordinary least squares, which is the 'normal' regression method. Also see Devereux and Fan (2011) for an IV 'natural experiment' approach using UK data.

<sup>28</sup> This follows work by Blundell et al. (2001) and Chevalier et al. (2003).

- Fasih et al. (2013), in contrast, find with international literacy survey data that there is a dichotomy between two groups of countries. For some educationally advanced countries, nearly half of the return to schooling can be attributed to labour market-relevant functional literacy skills, whereas for a subgroup of less educationally advanced countries, such skills account for around 20% of the return to schooling, the remainder mostly reflecting the signalling value of schooling.

### 3.3 The non-financial (non-pecuniary) returns to education

Paucity of data in developing countries has generally led to a greater focus on the economic (financial) returns to education rather than the non-financial returns (not related to wages).<sup>29</sup> These *non-pecuniary returns* include effects of education on health outcomes, on crime, on fertility behaviour and on a range of other outcomes, including savings behaviour and political participation. In addition, there are returns in the form of spillovers or externalities to the outcomes and the behaviour of others, for example friends and family.

The majority of research on the links between education and non-pecuniary outcomes has been conducted in developed countries, particularly the US and the UK, principally reflecting greater availability of multi-year datasets. Inferences can be drawn from some of this research for developing countries, but there is also an emerging literature on the developing world. The discussion below draws on both.

#### Education leads to better health and longevity, as knowledge improves behaviours

There are strong correlations between the education level of individuals and their own health outcomes observed in Western countries: in 2000, white males in the US with at least some college education could expect to live 6.2 years more than their less educated counterparts (Meara et al., 2008). There is also evidence that the health returns to education in the US have increased over time. During the 1990s, the life expectancy of those attending university increased an additional 1.6 years, but those who did not go to university experienced no change in the period (Cutler et al., 2011).

Estimates from IV and RD analyses (see Annex B for a description of these methods) test the effects of education on health from greater education received as a result of changes in schooling laws:

- Lleras-Muney (2005) estimates the causal effect of schooling on mortality in the US using state-level differences, estimating that each extra year of schooling reduces 10-year mortality rates by about 6 percentage points.<sup>30</sup>
- Clark and Royer (2010) and Albouy and Lequien (2009) use national increases in compulsory schooling ages in the UK and France, respectively, to estimate changes in educational attainment and mortality for the first cohorts affected by increases in compulsory schooling ages. Both, though, estimate statistically insignificant effects.

---

<sup>29</sup> The difficulty for empirical research exploring the potential links from education to non-pecuniary outcomes is again the presence of other omitted variables that are correlated with outcomes and more likely to cause them. A number of empirical approaches, including IV and regression discontinuity (RD) methods, are used to address this concern (see Annex B).

<sup>30</sup> Expanding the sample to include 1960-2000 US Censuses, Mazumder (2008) estimates that controlling for state-specific cohort trends produces negligible estimated effects of education on mortality.

**Box 5: Causal mechanisms linking education and health**

In terms of the causal channel for the relationship between education and health, there are a few that have been found to be important for developed countries:

- **Knowledge on health behaviours:** Aizer and Stroud (2010) show that knowledge about the harms of smoking in the US increased more quickly among the most educated following the 1964 Surgeon General's warning.
- **Knowledge and the ability to access health services:** Lange (2011) and Aizer and Stroud (2010) conclude that those with more education are better informed and this affects their health decisions, including taking cancer screenings and informing smoking decisions. Lange (2011) posits this may be because more educated women are more receptive to scientific evidence. Glied and Lleras-Muney (2008) find that more educated individuals experience greater survival advantages for diseases that showed the fastest technological progress. They argue that more educated individuals may be more likely to adopt new treatments and medicines.
- **Patience, risk aversion, behavioural spillovers:** Other channels that have been identified as potentially important include that education could lead individuals to be more patient, could make people risk averse or may affect the set of people individuals interact with on a daily basis in school, work or their neighbourhood (Lochner, 2011).

**There are strong links between receiving less education and committing more crime**

Studies on the links between education and crime are also mainly from Western contexts, again drawing on correlations: in 1997, over two-thirds of all prison inmates in the US were high school dropouts; in 2001, more than 75% of convicted persons in Italy had not completed secondary education; and prison rates among men aged 21-25 in the UK were more than eight times higher for those without an education qualification relative to those with a qualification (Lochner, 2011).

There is some strong evidence that this link is causal:

- Machin et al. (2011) exploit the 1972-1973 increase in the minimum schooling age (from age 15 to 16) in England and Wales and estimate that a one-year increase in average schooling levels reduces conviction rates for property crime by 20-30% and violent crime by roughly 10-15%. They find the most likely causal link for this relationship to be via higher earnings.
- Grogger (1998) estimates a significant negative effect of wages on crime, but finds no relationship between years of schooling and crime after controlling for individual wage rates.

**Box 6: Strong evidence from the US for a link between early childhood interventions and future reductions in incidence of crime**

In addition, there is strong evidence of early childhood interventions reducing crime later in life, in particular in the US, for two programmes offering half-day preschool at ages three and four – the Chicago Child Parent Center (CCPC) and the Perry Preschool in Michigan. The Perry Preschool was evaluated as a randomised trial, and Reynolds et al. (2001) used matching of treated children with comparison children to assess the CCPC. The Perry Preschool had significant effects on lifetime crime measured as of age 40. The CCPC reduced arrest rates by age 18 by about one-third (Lochner, 2011).

**Education increases political participation, if voting is a voluntary action**

The idea that education may instil civic and democratic values goes back to Lipset (1959) and even further back to Aristotle. Studies have again exploited variation in compulsory schooling or minimum work age laws, with sizeable effects of schooling on

voting behaviour found in the US, but weaker and statistically insignificant effects in the UK and Germany (ibid.). In the US, those who have been through tertiary education enrolment are 30-50% more likely to vote (Dee, 2004); completion of upper-secondary schooling increases voting by 40-70% (Milligan et al., 2004). The larger impacts of education on voting in the US may be explained by voter registration being voluntary while it is mandatory and the responsibility of local governments in the UK and elsewhere in Europe (ibid.).

### 3.4 Education and spillovers

The returns to education do not accrue just to the individual, but may lead to impacts and behavioural changes in peers, friends and neighbours. The largest impacts are likely to be on one's own children and family members, but education may also affect co-workers, neighbours, community members and others one interacts with on a frequent basis. To the extent that more educated persons interact more with other educated persons, effects of education on outcomes such as health may be increased through behaviour to conform or the spread of health-related information. Such 'social multiplier' effects could provide public benefits not taken into account when schooling decision are made. This argument in fact provides the foundation for why education is considered a merit good (see 1.2).

#### Education begets education

One of the strongest relationships in the education economics literature is between a parent's education level and a child's education level. Estimates of the elasticity for intergenerational mobility in education lie between 0.14 and 0.45 in the US and 0.25 and 0.40 in the UK.<sup>31</sup> However, it is difficult to assess whether it is education itself that causes the observed correlations between parents' and children's' education, or the transmission of ability genetically, or whether it is simply the fact that parents with more education earn more and therefore invest more in education. Genetic endowment is controlled for in some papers using a sample of adopted individuals. For example, Tsou et al. (2011) find that Taiwanese adoptees raised by more educated parents have higher educational attainment, suggesting the link is independent of genetic transmission of ability. Chevalier et al. (2005) use panel data from the UK Labour Force Survey and find parental education does not have an independent effect when exogenous variation in permanent income is controlled for. This suggests the primary reason education begets education is that it also begets higher incomes.

#### Education of parents improves the health of their children

The importance of parental education in helping improve child health is well established.<sup>32</sup> There are several mechanisms through which higher parental education translates into improved child health. One explanation is that better education translates into greater health care utilisation, that is, knowledge of when to access health care. More educated parents may also earn 'more' and be more 'empowered', and hence may be more able to allocate greater resources to child well-being (Caldwell, 1979). Educated mothers may also have better health knowledge and may more readily adopt modern medical practices (Barrera, 1990; Caldwell et al., 1989) or be more able to communicate with health workers and doctors. Education may also influence smoking and other health-related behaviours during pregnancy (Currie and Moretti, 2003).

There is also strong evidence from the developing world, particularly in Asia, that more educated parents make improved investments in children's health outcomes. Breierova and Duflo (2004) used a large school building programme in Indonesia in the 1970s to estimate that more education in the household reduced child mortality. A study by Chou,

<sup>31</sup> See Dearden et al. (1997) for the UK and Mulligan (1999) and Solon (1999) for the US.

<sup>32</sup> See Behrman and Deolalikar (1988) and Strauss and Thomas (1995).

et al. (2010) in Taiwan similarly found very large effects on birth outcomes of parental education, with estimates suggesting that the expansion of junior high schools increased schooling levels by 0.11 to 0.16 years and reduced the incidence of low birth-weight children by 5% and infant mortality by 8-19%. Glewwe (1999) used data from Morocco, finding that maternal health knowledge, linked to literacy and numeracy skills acquired during school, constitutes the key skill needed to raise child health outcomes. A study by Aslam and Kingdon (2012) in Pakistan also finds that, while fathers' education is positively associated with the 'one-off' immunisation decision, mothers' education is more associated with longer-term health outcomes of children. The analysis reveals that the mother's health knowledge and her empowerment within the home are the channels through which her education has an impact on her child's health outcomes.

### Education and peer health effects

Finally, there may be spillover effects of education on the health and health behaviours of one's peers. There is evidence regarding the peer effects associated with smoking and other health outcomes. Recent studies use IV techniques to estimate the influence of peers on smoking and drinking among school-age adolescents (see Annex B on methodologies for an explanation of IV). These studies typically find statistically significant peer effects; however, the size of impact varies considerably.<sup>33</sup>

## 3.5 Parental choice: the importance of perceived returns

The principal decision makers in education are first and foremost the parents of a child. If education is primarily an investment, parents will invest in their child's education if the returns are greater than the costs. However, it is not obvious what the returns to education are, as the returns are so far into the future. This highlights the importance of *perceived returns to education*, which may or may not reflect actual returns accurately. In particular, it is the perceived rather than actual returns to schooling that are likely to ultimately determine parental schooling choices, and this may be problematic when the perceived returns are incorrect (Jensen, 2010a).

### **Box 7: Parents underestimate the consistency of returns to each year of education**

Parents may underestimate returns to education, and may underinvest in their child's schooling as a result. As set out in Duflo and Banerjee (2011), there is a particular challenge if parents perceive the returns to education as an S-shape, rather than as a continuum – with low returns for early levels of education and returns materialising only once a key certification is achieved. For example, in Madagascar parents believed that each year of primary education would increase a child's earnings by 6%, each year of junior high education by 12% and each year of senior secondary education by 20%; in reality, the returns to each level were roughly even (Nguyen, 2008).

Perceived returns have also been seen to have an impact on choices between different children. Akresh et al. (2012) in Burkina Faso found children were less likely to be enrolled in school when their siblings scored highly on an intelligence test.<sup>34</sup> This suggests parents are more likely to be 'putting eggs into one basket', in terms of placing their hopes in one child getting through the whole of education and achieving the perceived higher associated returns, at the expense of their siblings.

<sup>33</sup> See Fletcher (2010); Gaviria and Raphael (2001); Lochner (2011); Norton et al. (1998); and Powell et al. (2005) for a summary.

<sup>34</sup> Having a higher-ability sibling lowers current enrolment by 15% and having two higher-ability siblings lowers enrolment by 30%.

## 4 Education systems in developing nations

### Key messages

- **Primary education is now, in principle, free and compulsory in nearly all countries.**
- **Enrolment in education has gone up across the world, but still lags behind in SSA and south-west Asia; as a result, 61 million children of primary school age are still out of school.**
- **Within countries, those from poorer, more rural backgrounds and those who are female tend to have less chance of being enrolled.**
- **The quality of education is a major concern, as shown by a number of international standardised tests – many children in South Asia and SSA in Grade 6 are not even at Grade 2 level.**
- **Teacher absenteeism may be a major cause of poor learning performance in the developing world.**
- **A large amount of education expenditure is by households on private schooling, with growing evidence of better quality in this sector.**

### 4.1 Universal education in developing countries: a very brief history

The goal of universal primary education (UPE), now one of the MDGs (MDG 2) for 2015, is not a new one. Asian governments meeting in Karachi in 1959 agreed a target of universal free and compulsory primary education for 1980, and African leaders met in Addis Ababa in 1961 to agree the same.<sup>35</sup> Significant progress was made in the following two decades, with SSA's gross enrolment rate (GER) up from 45% in 1960 to 80% by 1980. Progress in the region then stagnated, going down to 72% by 1992; a pattern shown by Fredriksen (2009) for Kenya, Ghana, Tanzania and Zambia, where 'a combination of worsening economic conditions, reduced education budgets, and re-emergence of school fees led to the reversal of earlier gains of fee abolition'.

But progress has recently been made, as countries again respond to the UPE agenda. Now only a handful of countries do not enshrine the principle of compulsory education in law.<sup>36</sup> In terms of school fees, in 2005 a UN report by Tomasevski (2006) found that 32 countries were still charging school fees for primary education, all but 7 in SSA.<sup>37</sup> This number is likely to have reduced, with many of these countries removing fees.<sup>38</sup> However, while education can be formally 'free', in practice parents must still face a number of costs, as shown in Table A1 for Ghana in Annex A.

Success at the primary level has more recently seen the agenda move towards secondary education. In 2007, Uganda became the first country in SSA to introduce

<sup>35</sup> Subsequently a target for the year 2000 was agreed in 1990 under the worldwide Education For All (EFA) initiative in Jomtien, Thailand, and in the EFA initiative in Dakar in 2000, again for 2015.

<sup>36</sup> Papua New Guinea, Vanuatu, the Maldives, Nepal, Somalia and South Sudan (UNESCO, 2014). Recent changes include Liberia in 2008, The Gambia in 2004 and Burundi in 2005. Ethiopia plans to implement in 2015.

<sup>37</sup> The definition of free education is that no charges are levied for enrolment and tuition, but the practice varies beyond that minimum. Free education may or may not include a range of subsidies provided to offset the cost of enrolment: tuition, books, meals, computers, sports and even transportation (Tomasevski, 2006).

<sup>38</sup> With free education laws and policies in The Gambia and Indonesia in 2005, Benin and Ghana in 2006, Kyrgyzstan and Liberia in 2007 and Colombia and Swaziland in 2010.

universal secondary education. Under its scheme, students who get specific grades in each of the four primary school-leaving exams can study free in public schools and participating private schools.<sup>39</sup>

## 4.2 Education today: an overview

### Educating a greater proportion of children with fewer resources

Education systems in developing countries face a double bind, with lower levels of resources and a greater number of children as dependants to educate:

- **Inequalities in income between countries are large.** In 2013, the richest 50 countries had an average GDP per capita of \$41,000, compared with \$9,000 for the next 50 countries and just \$900 for the poorest 50 countries.<sup>40</sup> This means expenditure available for education from public and private sources is also low.
- **Demographic contrasts are also stark.** The proportion of the population aged under 15 is 42% in SSA and 32% in south Asia, compared with just 17% in high-income countries.<sup>41</sup> This means there are more children to educate and a relatively smaller tax-paying, working population to support them.

### Enrolment rates for levels of education have improved in recent years

Despite the scale of the challenge, there have been increases in enrolment ratios globally in the past decade or so, as shown in Table 2<sup>42</sup>. Low-income countries, particularly in SSA and south and west Asia have seen primary enrolment increase significantly, although this has not yet been reflected in the survival ratio to the last grade of primary. Secondary and tertiary rates have also almost doubled in these regions, although both remain relatively low compared to other regions, particularly upper secondary for SSA with just a 32 per cent GER, and just an 8 per cent GER for tertiary levels in 2011.

**Table 2: Enrolment ratios for primary, secondary and tertiary education**

	Primary adjusted net enrolment ratio		Survival rate to last grade of primary education		Lower-secondary gross enrolment ratio		Upper-secondary gross enrolment ratio		Gross enrolment tertiary	
	1999	2011	1999	2010	1999	2011	1999	2011	1999	2011
<b>World</b>	84%	91%	74%	75%	72%	82%	45%	59%	18%	30%
<b>Low-income countries</b>	59%	82%	55%	59%	36%	54%	23%	31%	4%	9%
<b>Lower-middle-income countries</b>	79%	90%	68%	69%	61%	77%	31%	48%	11%	19%
<b>Upper-middle-income countries</b>	95%	97%	85%	90%	88%	96%	52%	75%	14%	33%
<b>High-income countries</b>	97%	98%	92%	94%	102%	105%	97%	100%	58%	73%
<b>SSA</b>	59%	78%	58%	56%	29%	49%	21%	32%	4%	8%
<b>South and West Asia</b>	77%	93%	62%	64%	61%	76%	30%	47%	7%	16%

Source: UNESCO (2014). Tertiary level from WDI; South Asia used instead of South and West Asia for tertiary-level stats.

<sup>39</sup> See <http://www.theguardian.com/global-development/poverty-matters/2011/oct/25/free-secondary-education-uganda-mixed-results>

<sup>40</sup> Data for 181 countries from the World Bank's World Economic Outlook (WEO) 2013.

<sup>41</sup> World Bank World Development Indicators (WDI) 2013.

<sup>42</sup> A period that has coincided with growth averaging over 5 per cent in SSA (2001-2013) (World Bank, 2013).



## There are 61 million out-of-school children worldwide, over a third of them in SSA

Enrolment increases have led to reductions in the number of out-of-school children of primary school age worldwide. Figure 2 shows the largest drop as having been experienced in the period from 1999 to 2007. Progress has stagnated somewhat since then, with 61 million children remaining out of school as of the latest data. The majority of such children – around 25 million – are in the SSA region, and close to half of these – 10.5 million – are in Nigeria. Pakistan has the second highest number for any country, with 5.4 million, followed by 1.7 million in both Ethiopia and India.<sup>43</sup>

**Figure 2: Number of out-of-school children from 1999 to 2010, by region**

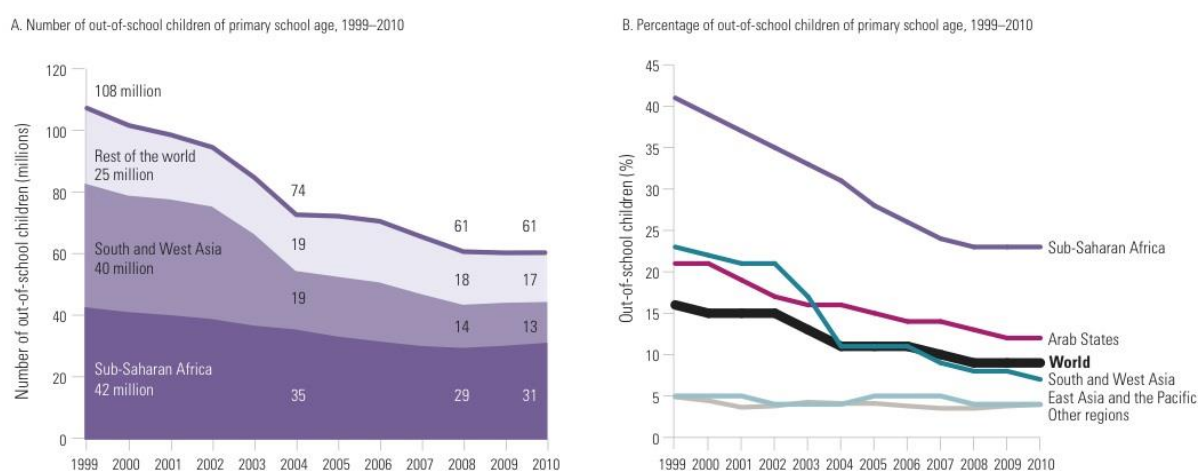

Source: UNESCO (2012a).

### Box 8: Data limitations in estimating out-of-school children in developing countries

There are still significant uncertainties around the numbers of out-of-school children worldwide. Official data come from just 147 out of 204 countries, with unpublished estimates by the UN Educational, Scientific and Cultural Organisation (UNESCO) Institute for Statistics (UIS) used for the remaining countries.<sup>44</sup> Countries without data include those affected by conflict, such as the Democratic Republic of Congo and Somalia, where the chances of going to school remain slim. In addition, most countries in Latin America publish data, but Brazil, for example, does not, because of disputes over population figures. Recent improvements in the availability of household survey data have been used to clarify the global picture (UNESCO, 2014).

### Within-country variation is almost as high as between-country variations in enrolment

Enrolment averages reported above mask large inequalities in access within countries based on region, gender, caste, religion and socioeconomic status. As Figure 3 shows for Ethiopia, incidence is much higher in rural areas than in urban areas, with girls seeing a higher incidence of being out of school than boys. This within-country variation is

<sup>43</sup> There are 14 countries with over 1 million primary-aged out-of-school children – Afghanistan; Burkina Faso; China; Côte d'Ivoire; Democratic Republic of Congo; Ethiopia; India; Kenya; Nigeria; Pakistan; the Philippines; Somalia; Sudan (pre-secession); and Tanzania (UNESCO, 2014).

<sup>44</sup> However, even the official data supplied by education ministries may be of questionable accuracy. Analysis for EFA 2010 found that, when compared with household survey data, school registers tend to count more children within the official primary school age range. The difference was over 10 percentage points in 10 out of 29 countries covered; in Tanzania, for example, it was equivalent to 25 percentage points in the net enrolment ratio (Bruneforth, 2009).

prevalent in many other countries and extends to the chance of completing school.<sup>45</sup> In Benin, for example, 60% of the poorest quintile of children enrol, with 51% surviving to the last grade of primary school; this compares with 95% and 90% for the richest quintile's entry and survival rate, respectively (UNESCO, 2014). In India, disparities are rife between states, with Grade 5 survival rates of 97% in Tamil Nadu compared with 73% in Gujarat (ibid.). More data on inequalities are provided in Annex A, including Figure A3 for disabled children and Figure A4 for inequalities by wealth quintile.

**Figure 3: Ethiopia, 7-16 year olds who have never attended school (%)**

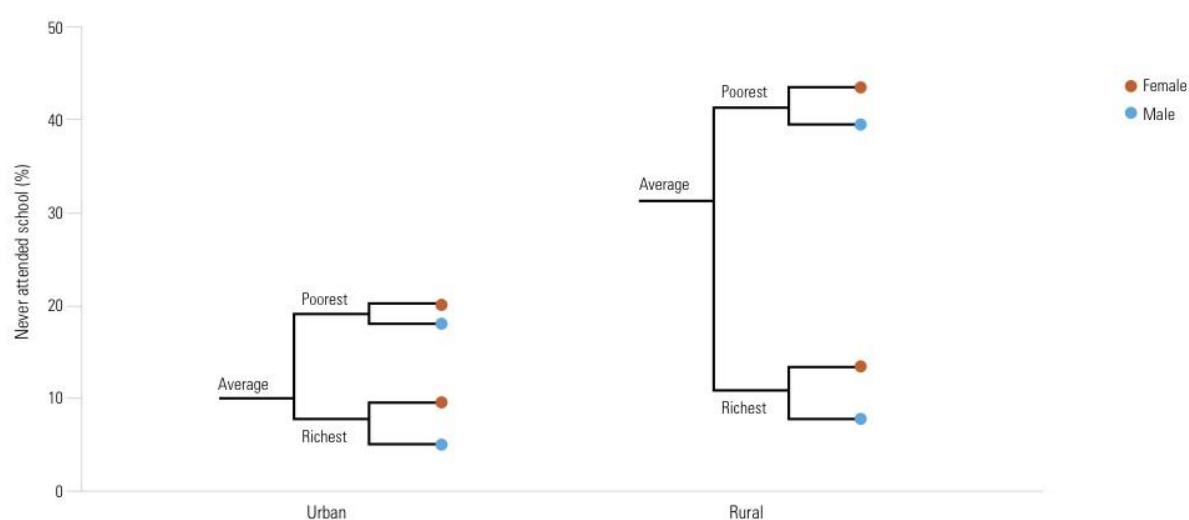

Note: 'Poorest' and 'richest' refer to the bottom and top 20%, respectively.

Source: UNESCO (2012a).

### 4.3 Education today: new evidence from basic skills tests

#### *Quality of education in developing countries is clearly lagging behind quantity*

While enrolment gives a rough indication of the *quantity* of education undertaken, there is plenty of evidence that the *quality* of education should be of equal concern. As mentioned above, evidence is increasingly available on a number of internationally comparable tests on learning outcomes, in particular for basic skills in literacy, numeracy and some core subjects such as science. These show that the number of years of schooling in one country may imply a different level of learning than it does in another.

Developed by the Indian non-governmental organisation (NGO), Pratham, and conducted annually across rural India since 2005, the Annual Status of Education Report (ASER) is the pioneering basic skills test in a developing country context. This has led to other spin-off tests, and a number of worrying results:

- The initial ASER assessments showed that nearly 60% of children in Grade 4 could not read a simple story at Grade 2 level, and 76% could not do simple division (Pratham, 2005). Subsequent annual evidence from ASER in India has shown that, if anything, performance on basic skills tests has got worse (Pritchett, 2014).
- In 2009, ASER was extended to neighbouring Pakistan, where in 2012, 80% of rural children in Class 3 could not read a simple English sentence, while over a third could still not do so at Class 6 (ASER Pakistan, 2012). ASER Pakistan now

<sup>45</sup> Poorer, more disadvantaged children are also more likely to enrol late in primary school. In Rwanda, 70% of the poorest quartile enrolls late compared with just 50% of the richest; in Nigeria, late entry for the richest is just 11%, compared with 37% for the poorest.

covers all districts across Pakistan; the most recent report continues to highlight worryingly low levels of learning among children aged 5-16 in rural parts of the country.

- In 2007, Uwezo (which means 'capability' in Kiswahili) developed an East African version of the ASER literacy and numeracy tests, conducting them annually for Kenya, Uganda and Tanzania. As in South Asia, results have been disappointing: in Kenya, around half of Grade 3 children cannot read even a simple paragraph in English or Kiswahili (Uwezo, 2012).

These large-scale assessment exercises demonstrate that children in developing countries are failing to master basic literacy and numeracy skills – so, while quantity of education is apparently increasing, quality apparently is not. This is further illustrated in Figure 4, which presents combined data from a range of tests to show that cross-country inequality in learning outcomes is much higher than for educational participation,<sup>46</sup> with less than 20% of Grade 4 students achieving the 'minimum level' of learning in seven countries, including Uganda and Malawi, despite the rise in participation.<sup>47</sup>

**Figure 4: Cross-country inequality in primary school participation and learning outcomes<sup>48</sup>**

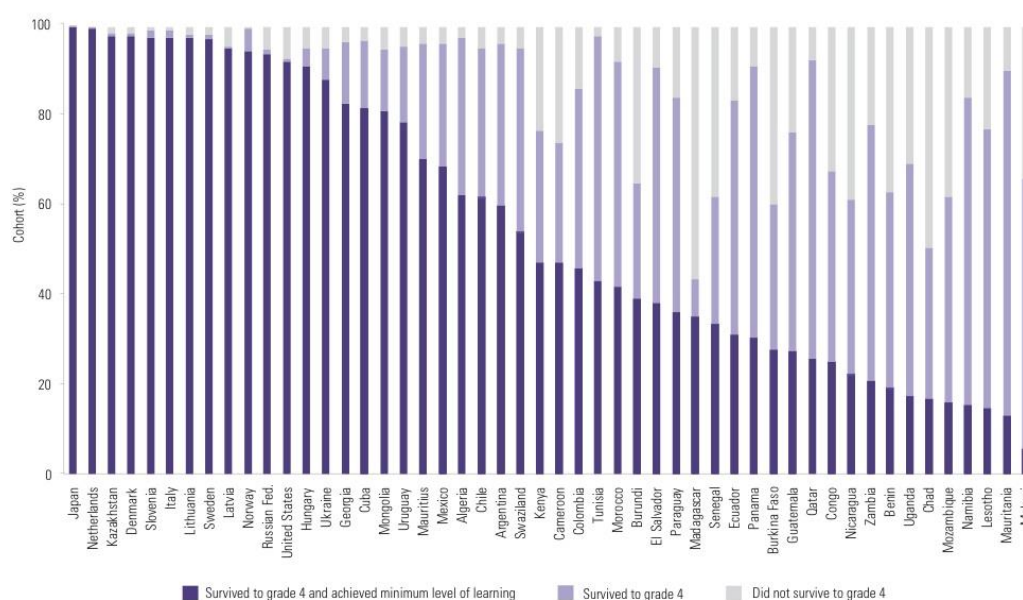

Source: UNESCO (2012a).

## 4.4 Education systems: high teacher absenteeism, low teacher effort

### Teacher absenteeism is extremely high and associated with lower learning outcomes

Low teacher effort can be proxied by levels of absenteeism observed among them. This low effort is often seen as a key factor explaining the dismal levels of achievement

<sup>46</sup> Internationally comparable evidence includes PISA (available for 73 countries, high and middle income), the Southern and Eastern Africa Consortium for Monitoring Educational Quality (SACMEQ) (14 Eastern and Southern African countries), the Progress in International Reading Literacy Study (PIRLS) (59 countries, high and middle income), the Trends in International Mathematics and Science Study (TIMSS) (76 countries, high and middle income), the Programme for the Analysis of Education Systems (PASEC) (24 francophone African countries) and the Latin American Laboratory for Assessment of the Quality of Education (LLECE) (18 Latin American countries) (UNESCO, 2014).

<sup>47</sup> As with enrolment, there are big variations within countries between the richest and poorest on skills tests. The proportion of rich children being able to reach Level 2 mathematics at age 10 is double the proportion of poor children for most countries (based on analysis of PISA data in UNESCO, 2014).

<sup>48</sup> The percentage of a cohort reaching Grade 4 and achieving a minimum learning level in mathematics in four regional and international learning assessments.

among children in many developing countries. Recent studies have documented teacher absence rates as especially high in certain developing country contexts. For example, the 2002/03 World Absenteeism Survey of six countries, led by the World Bank, found that, in Bangladesh, Ecuador, India, Indonesia, Peru and Uganda, teachers miss one day of work out of five on average (one in four days in India and Uganda).<sup>49</sup> The problem, therefore, appears to be one of *no teaching* rather than poor quality teaching. Furthermore, this is a bigger problem in poorer areas, as Kremer et al. (2005) found for India, with teacher absenteeism varying from 15% in Maharashtra and 17% in Gujarat – two richer and more urbanised states – to 38% in Bihar and 42% in Jharkhand, two of the poorest states.

#### **Box 9: Low teacher attendance connected to financial concerns and low pay**

Teacher absence appears to be driven by low motivation arising from low pay. In Malawi, where teachers' pay is low and payment often erratic, 1 in 10 teachers stated that they were frequently absent from school in connection with financial concerns, such as travelling to follow up and collect salaries or securing credit and making loan payments (Moleni and Ndalama, 2004). Teachers may also be absent because of poor management practices. Head teachers are also often absent, impeding effective monitoring of teacher attendance.<sup>50</sup> Aslam et al. (2013) argue that the nature of incentives that arise as a result of permanent, tenured positions in government jobs (where a majority are) rather than low salaries of in South Asia may contribute to their high levels of absenteeism and resultant poor effort.

There is substantial evidence that students' learning is affected by high rates of teacher absenteeism. In India, for example, a 10% increase in teacher absence was correlated with 1.8% lower student attendance (Kremer et al., 2005). In Zambia, an increase in teacher absence by 5% reduced the learning gains that Grade 5 students made over the year by about 4% in English and mathematics (Das et al., 2007).<sup>51</sup> The problem may be partly addressed by performance pay (discussed in Chapter 5, Section 5.4).

## 4.5 Education systems: public private divide

### Private provision of education is on the rise

Recent years have seen a mushrooming of private sector education provision. Problems of low quality in state schools and high levels of teacher absence are among the most cited explanations for this trend (Ramgaraju et al., 2012). Table 3 shows how much governments and households contribute to total education expenditure. This can be seen as a rough proxy for the scale of education provided by the private sector in SSA. Estimates range from over 40% of total educational expenditure in Burkina Faso and Sierra Leone to as little as 2% in Zambia. The mushrooming of low-fee private schools in developing countries has led to the emergence of a large literature since the late 1990s.<sup>52</sup> Opinion remains strongly divided regarding the significance of the private sector in meeting the demands of the UPE agenda. On the one hand, proponents argue that private schools reach more children and are able to provide better-quality schooling; on the other, sceptics argue that private schools continue to be accessed by an elite or the 'less poor'.

<sup>49</sup> See <http://wbi.worldbank.org/wbi/devoutreach/article/1068/why-arent-children-learning>. A further study of five developing countries found a 19% teacher absence rate (Chaudhury et al., 2006) and that teachers were not in front of the class when they should be close to half the time.

<sup>50</sup> A 2011 survey of schools in Uganda found that, on average, 14% of teachers and 21% of head teachers were absent on the day the schools were visited (Uwezo Uganda, 2011).

<sup>51</sup> In Indonesia, a 10 percentage point increase in teacher absenteeism was estimated to lead to a 7 percentage point decrease in mathematics scores (Suryadarma et al., 2006).

<sup>52</sup> See McLoughlin (2013) for an excellent summary of evidence on low-cost private schools.

**Table 3: Household and government expenditure on education (% of GDP)**

	COUNTRY	GOVERNMENT EXPENDITURE ON EDUCATION (% OF GDP)	HOUSEHOLD EXPENDITURE ON EDUCATION (% OF GDP)	HOUSEHOLD EXPENDITURE ON EDUCATION AS A % OF ALL EXPENDITURE ON EDUCATION
GDP per capita < PPP\$1,000	Sierra Leone (2003)	4.2	3.2	43.6
	Malawi (2004)	4.2	1.6	27.2
	Niger (2005)	...	0.6	...
GDP per capita of PPP\$1,000-3,000	Burkina Faso (2007)	3.1	2.3	42.5
	Chad (2001)	3.9	2.1	34.7
	Benin (2003)	2.2	1.1	33.9
	Madagascar (2001)	3.3	1.6	32.5
	Côte d'Ivoire (2002)	4.4	2.0	30.9
	Cameroon (2001)	3.3	1.2	26.7
	United Republic of Tanzania (2007)	3.6	1.0	21.9
	Nigeria (2003)	3.6	1.0	21.2
	Mali (2006)	3.3	0.7	17.9
	Zambia (2004)	2.8	0.1	1.8
	Rwanda (2005)	3.6	-	0.6
GDP per capita > PPP\$3,000	Gabon (2005)	8.6	4.8	36.1
	Congo (2005)	5.1	0.7	11.3
	Average (16 countries)	3.9	1.5	25.5

Source: UNESCO (2011).

### Differences in teacher absenteeism, costs and learning outcomes: public vs. private

There is significant evidence of differences between private and public education in terms of the behaviour and recruitment of teachers (more information is provided in Chapter 5, Section 5.7.) and on learning outcomes. In particular:

- Different rates of teacher absenteeism:** In the state of Andhra Pradesh in India, teacher absenteeism in private schools was 9 percentage points lower than in government schools (Singh and Sarkar, 2012).<sup>53</sup> The credible threat of dismissal in private schools is believed to be a reason for lower teacher absence compared with in the state sector, where 'jobs for life' distort incentives.
- Differences in teacher costs:** One of the main reasons why private schools are seen as more 'cost effective' is because their recruitment of teachers, usually women, is at lower cost than that in government schools.<sup>54</sup> In Uttar Pradesh and Madhya Pradesh, teachers' salaries in low-fee private schools are one-eighth of government teachers' salaries in the same district or village (Goyal and Pandey, 2009). In Kenya, across four districts, low-fee private school teachers receive around half the basic pay of a government teacher and lack the pension and health insurance arrangements government teachers are entitled to (Stern and Heyneman, 2013).<sup>55</sup>
- Lower class sizes may mean private school teachers provide more feedback to their pupils:** In Andhra Pradesh, around half of teachers in both private and government schools used traditional methods of teacher-directed instruction, but private school teachers offered more feedback to students: 82% of teachers in private schools regularly corrected exercises given to children, compared with 40% of teachers in government schools (Singh and Sarkar, 2012).

<sup>53</sup> Teacher absenteeism is also prevalent in low-fee private schools, often because teachers receive low salaries and hence need to take on additional work. In Lagos, 11% of private school teachers were absent during unannounced visits (Härmä and Adefisayo, 2013). In rural Pakistan, absenteeism was 13% among government school teachers and 12% at private schools (ASER Pakistan, 2012).

<sup>54</sup> In Andhra Pradesh, India, women make up 69% of the mathematics teacher workforce in private schools but only 34% in government schools (Singh and Sarkar, 2012).

<sup>55</sup> In a slum area of Lagos, private school teachers get a wage of around \$80 per month, compared with the state's minimum wage of \$116 and the starting salary for a government teacher of \$167 (Härmä, 2011).

A survey in Lahore district in Punjab province of Pakistan showed private school teachers were more likely to try to identify what pupils actually understood, by asking them questions in class, and also spent more time planning their lessons. This made a significant impact on pupils' learning (Aslam and Kingdon, 2011).

- **Learning outcomes of students in private schools are at par (if not better) than those in government schools:** A review by Day Ashley et al. (2014) provides evidence from literature on private schools across the developing world from 2000 and concludes there is strong evidence that teaching is better in private schools than in state schools, in terms of higher levels of teacher presence and teaching activity as well as teaching approaches that are more likely to lead to improved learning outcomes. They find moderate evidence to suggest private school pupils achieve better learning outcomes when compared with state school pupils – with 14 out of 21 studies looked at showing privately schooled children learning more, although many not adequately controlling for differences in the social background of these children.

## 5 Education policy, interventions, evidence

### Key messages

- An array of interventions has been utilised to try to improve the quantity and quality of education in developing countries. Economists tend to view these as *inputs* into an *education production function*.
- In recent years, studies assessing interventions have become more rigorous, particularly with the use of randomised control trials (RCTs).
- This evidence has demonstrated that supply-side interventions involving the presence and proximity of schools are particularly strongly associated with enrolment and learning.
- Supply-side interventions providing better 'materials' are less well evidenced, with a number of studies questioning the provision of textbooks and information and communication technology (ICT), particularly if not linked directly to classwork.
- Interventions aiming to improve teachers have mixed results. Teacher practices are found to be more important than *resumé characteristics*, and the use of contract teachers has been found to improve student outcomes.
- Demand-side interventions have a good and growing body of evidence – even the provision of information about what returns are – as well as reducing the income constraint by providing cash transfers or scholarships, particularly where these are *conditional* or even *labelled*.
- Interventions improving the 'preparedness' of young children for school, particularly improving child health, as well as early childhood development, also are strongly related to better education outcomes.

### 5.1 How economists assess education policy and interventions

This chapter provides an overview of evidence on what economists have found to work in terms of policies and interventions to improve education. 'What works' here is defined as interventions with significant impact on *quantity* measures such as enrolment and attendance, and/or *quality* measures, usually performance scores on tests of learning outcomes.<sup>56</sup> This evidence should be treated with caution when making inferences from one study to other contexts; as Fraser et al. (1987) note, 'in educational research, no single study, no matter how large, can be taken by itself as definitive'.

#### Assessment methodologies

To assess what is important in driving educational outcomes, economists use the idea of an *education production function*. Here, educational outcomes such as enrolment, attendance and learning are expressed as a function of schooling *inputs*. Inputs include those policymakers have some control over, such as school resources and quality of teachers, and those they have less (or no) control over, such as parental attitudes and behaviours (Hanushek, 2010). The education production function approach has been criticised, because inputs can be hard to measure; past inputs for which there are few data affect current outcomes; there is an endogeneity bias; and there is a problem of omitted variables, such as students' ability. Panel data, and IV and RD approaches, are

<sup>56</sup> The evidence is further discussed with respect to the VfM of interventions in Section 6.5.

all used to try to address these complications, although data requirements mean such studies have not been widely available for developing countries (see Annex B on methodologies).

In order to overcome many of the criticisms of the educational production function, over the past decade RCTs have engendered a revolution in educational research, along with other areas of development economics. RCTs assign a particular policy intervention to a *treatment group* and measure the outcomes achieved against a *control group*, which does not receive an intervention. The two groups should be well matched as they are randomly selected from a similar pool of schools and/or communities. RCTs therefore provide a robust strand of evidence for whether a particular intervention or policy works, as other factors are effectively *held constant*. This chapter draws on a range of evidence, including from RCTs, to assess what works in education.

## 5.2 Interventions in education

Interventions, policies and programmes in education can be viewed in terms of whether they target the 'supply side' or the 'demand side', or the two simultaneously. Supply-side interventions are those involving the provision of schooling, in terms of physical infrastructure of classrooms or inputs such as textbooks and teachers, as well as the organisation of the schooling system, such as the use of tracking (setting or streaming students by ability) or the design of teacher remuneration. Demand-side interventions focus on raising the incentive for parents and children to go to school and learn, including by raising the *perceived returns* to education, or by reducing/subsidising costs through *cash transfers* or scholarships. A typology of interventions is shown in Figure 5.

**Figure 5: Typology of interventions in education, summary of strength of evidence**

		Findings of this paper	Kremer and Holla (2009) - RCTs	Glewwe et al. (2011) – “high quality studies”	
Supply-side Interventions	Building schools	STRONG		STRONG	
	Materials	Textbooks	MIXED	MIXED	MIXED
		ICT / computers	MIXED	MIXED	MIXED
		Uniform provision	STRONG	STRONG	
		Sanitary provision	WEAK		
	Teachers	Performance pay	STRONG	MIXED	
		Qualifications	MIXED		MIXED
		Contract teachers	STRONG	STRONG	STRONG
		Attendance monitoring	STRONG	STRONG	
	School organisation	Length of the school day	STRONG		STRONG
		Tracking	STRONG	STRONG	MIXED
		Class sizes	MIXED	WEAK	MIXED
	Demand-side interventions	Providing information	STRONG	STRONG	
Reducing costs		Abolishing school fees	STRONG		
		CCTs / Scholarships	STRONG	STRONG	
		School feeding	MIXED	STRONG	STRONG
		Vouchers	MIXED	STRONG	
Preparedness		Early child development	MIXED		
		Health / nutrition	STRONG	STRONG	

Figure 5 summarises evidence for a typology of interventions, including from Kremer and Holla's (2009) summary of RCT evidence and Glewwe et al.'s (2011) review that identified 43 'high-quality' studies. In addition, the first column presents this paper's summary review, where evidence is assessed to be 'strong' if there is availability of multiple high-quality studies or RCTs showing statistically significant and sizeable



impacts on learning, enrolment or attendance measures. 'Mixed' evidence indicates less evidence or the presence of contradictory evidence. 'Weak' evidence indicates few studies and/or non-statistically significant results for those studies that exist.

### Supply of education: the education 'no-brainer' - presence of a school matters!

The first step to increasing education is the presence of schools, or, more specifically, the presence of schools within a sufficiently close distance for students to attend. Evidence from a study using an IV methodology for Indonesia and an RCT in rural Afghanistan shows significant proof that the presence of schools matters:

- Duflo (2001) uses an oil boom in 1973 and a subsequent school building spree in Indonesia to measure the effect of school infrastructure. She finds that children aged two to six in 1974 received 0.12 to 0.19 more years of education for each school constructed per 1,000 children in the region of birth – a significant impact of school presence.<sup>57</sup>
- Burde and Linden (2012) use an RCT in rural north-western Afghanistan, where children can walk as much as 10 km to attend school, to estimate that the presence of village-based schools increases formal school enrolment by 42 percentage points and test scores by 0.51 standard deviations on average, and 1.2 standard deviations for children who enrol. While all students benefit, the effects are larger for girls. They estimate that, for every mile a school is further away, enrolment falls by 16 percentage points and test scores by 0.19 standard deviations, with distance affecting girls more than boys.

### Demand for education: the effect of 'free' schooling is significant

For a parent, the expected marginal benefit of educating should exceed the marginal costs of schooling, including the *opportunity cost* of having a child out of school in terms of lost earnings or the value of household work. As such, it would be expected that the move towards free schooling in recent years would raise enrolment. It turns out this is the case; the impact of free schooling on enrolment is strongly evidenced. Fredriksen (2009) reports enrolment increases following fee abolition in five recent African cases. The increase in total primary school enrolment in the year following fee abolition was 12% in Mozambique, 14% in Ghana, 18% in Kenya, 23% in Ethiopia and 51% in Malawi.<sup>58</sup>

#### **Box 10: Increasing enrolment may have detrimental impacts on school quality**

Following implementation of free schooling, enrolment increases can have perverse impacts on the overall quality of schooling provided. Bold et al. (2011) find that the free primary education policy in Kenya led to a decline in public school quality, primarily because of the enrolment of weaker pupils into the system. More affluent children who responded to the policy by exiting the public system for private sector schools benefited from a huge exam performance premium of 2.5 standard deviations (see Section 5.7).

### Demand for education: disease prevention is also key for children to go to school

Disease prevention is another foundational factor for getting children into school. In one of the most celebrated early RCTs, Miguel and Kremer (2004) demonstrated that health of children, in particular their freedom from infections of worms such as hookworm, roundworm and schistosomiasis, had a substantial impact on school participation. Studying randomised deworming in Kenya at the school level, they found school

<sup>57</sup> Further, Handa (2002) finds that building more schools would have had a much larger impact on school enrolment in post-conflict Mozambique in 1996/97 than raising the incomes of household heads.

<sup>58</sup> In addition, increases in enrolment in the year following fee abolition have occurred in other countries; for example, Cameroon, 26% in total primary enrolment; Lesotho, 11% in total enrolment; Tanzania, 23% in total enrolment; and Uganda, 68% in total enrolment (Fredriksen, 2009).

absenteeism reduced by a quarter following deworming.<sup>59</sup> This is mirrored by the other major tropical blight, malaria, with over 200 million cases in 2010 and most deadly for under five year olds in Africa<sup>60</sup> – Burlando (2012) estimates that, in Ethiopia, moving from a village with no malaria to one with average malaria reduces schooling in children and adults by 0.3 to 0.6 years.<sup>61</sup>

### 5.3 Supply-side interventions: school materials

As shown above, the presence of schooling infrastructure is the first step towards education provision. Beyond that, supply-side interventions can focus on teaching materials, teachers themselves (training etc., see 5.4) and factors of school organisation (see 5.5). Materials can include school uniforms, textbooks, ICT and sanitary provision for girls, among other inputs. This section looks at evidence for education interventions seeking to improve some of these types of *school materials*.

#### Uniform provision: supply interventions stimulating a demand-side response

Many supply-side interventions are likely to operate via a demand-side response. This includes the provision of uniforms, which reduce the non-fee costs for parents of sending their children to school. Evans et al. (2009) evaluated the impact of an educational intervention in which a Kenyan NGO distributed school uniforms to children in poor communities, using a lottery to determine who would receive uniforms. They found school uniform provision significantly reduced school absenteeism, by 38%, and the effects were much larger for poorer students who did not previously own a uniform, with a 64% reduction in absenteeism. Thus, even following the abolition of fees in Kenya in 2003, and the provision of textbooks, the cost of uniforms appeared to be a barrier to education. As with any RCT, it can be argued that the findings are subject to some caveats – see Section 6.5 for more on extrapolating information from RCTs.

#### Textbooks: an example of the importance of how inputs are put to use

Summaries by Evans and Ghosh (2008), McEwan (2013b) and Glewwe et al. (2011) find evidence that textbooks improve learning across a broad range of countries. However, Glewwe et al. (2009), in a randomised evaluation in Kenya, found providing textbooks did not raise average test scores. They did find, though, that textbooks increased the scores of students at the higher end of the ability distribution, with little effect on other students. They speculated that, as textbooks are in English, most students' third language, many students could not use them effectively. The curriculum in Kenya, and in many other developing countries, tends to be oriented toward academically strong students, leaving many students behind. Furthermore, Kuecken and Valfort (2013) find in an estimate for African primary schools that only one form of textbook access – sharing, not ownership – has a positive impact on test scores for students in the highest percentile. This and other evidence indicates textbooks are unlikely to improve learning unless accompanied by a change in pedagogy and designed to suit the needs of all rather than a minority of students (see DFID, 2014).

#### Sanitary provision: little evidence for a popular intervention type

Despite becoming a popular method of intervention,<sup>62</sup> the provision of sanitary products to promote girls' attendance has little research to support it. The only rigorous

<sup>59</sup> Bobonis and Puri-Sharma (2006) evaluated a randomised intervention delivering iron supplements and deworming drugs to children in the slums of Delhi, India, where 69% were anaemic and 30% underweight at baseline. The programme increased the weight of children and preschool absenteeism decreased by 20%.

<sup>60</sup> <http://www.who.int/features/factfiles/malaria/en/> (accessed 8 February 2014).

<sup>61</sup> In addition, Lucas (2010) finds following malaria eradication in Paraguay and Sri Lanka that each 10 percentage point decrease in the incidence rate led to an increase in schooling of 0.1 years and an increase in the probability of being literate by 1 to 2 percentage points.

<sup>62</sup> Such as Proctor and Gamble pledging \$5 million toward providing puberty education and sanitary products.

randomised evaluation is by Oster and Thornton (2011), who look at sanitary product provision in Nepal for Grade 7 and 8 girls. They found menstruation had a very small impact on school attendance, and girls who randomly received sanitary products were no less likely to miss school during their period than those who received none. The authors state, 'Despite the money being spent on this issue, and the seeming media consensus on its importance, there is little or no rigorous evidence quantifying the days of school lost during menstruation or the effect of modern sanitary products on this time missed.'

### Computers and ICT: cautionary evidence on the high-tech hype

There has also been much focus in recent years on the growing potential of ICT for education.<sup>63</sup> In 2009, an average of 95% of 15-year-old students in OECD member countries had a computer at home, compared with about half in Brazil, Mexico and Thailand, and much lower proportions in less-developed countries. Many view this 'digital divide' as an educational divide, with governments and NGOs seduced by the potential of ICT. This has led to prominent initiatives such as the One Laptop per Child (OLPC) programme, which has seen over 2.5 million laptops distributed to children in more than 52 countries (Beuermann et al., 2013).

Evidence to date is not strong on the link from ICT to educational performance. Beuermann et al. (2013) evaluated an RCT distributing OLPC XO laptops for home use to children attending primary schools in Lima, Peru. Treatment children scored almost one standard deviation higher in a test of general proficiency with their laptop, but there were no effects on skills using a Windows-based PC or the Internet. In addition, Cristia et al. (2012) evaluated the OLPC programme in rural Peru and found no impacts on academic achievement in maths and language standardised tests,<sup>64</sup> although they observed some positive and significant impacts on cognitive skills. Other evidence has even found computer use can have negative effects on school exam performance.<sup>65</sup>

#### **Box 11: Successful ICT interventions may be driven by their intelligent use and combination with basic skills**

The missing link for computers may, as with textbooks, be in how effectively they are used, particularly in targeted learning programmes. Banerjee et al. (2007) evaluate a computer-assisted learning programme, where instructors from an NGO, Pratham, provided children with two hours of shared computer time per week. Children played educational computer games emphasising basic competencies in the official mathematics curriculum. All interaction between the students and instructors was driven by the child's use of the various games, and at no time did any of the instructors provide general instruction in mathematics. The intervention was a success, increasing maths scores by 0.35 standard deviations the first year and 0.47 standard deviations in the second year, and this was equally effective for all students.

## 5.4 Supply-side interventions: improving teachers

### What makes a high-quality teacher: *resumé* characteristics or classroom practices?

Variations in teacher effectiveness are perhaps the most important determinant of differences in school quality (see Hanushek and Woessmann, 2011). However, identifying what it is about the teacher – qualifications, subject-specific knowledge or

<sup>63</sup> See <http://www.economist.com/news/leaders/21580142-long-overdue-technological-revolution-last-under-way-e-ducation>

<sup>64</sup> Fairlie and Robinson (2012) on home computer use in the US also found no impacts on academic achievement. Angrist and Lavy (2002), Krueger and Rouse (2001), Leuven et al. (2004) and Machin et al. (2006) find little or no effect of computerised instruction on test scores.

<sup>65</sup> Malamud and Pop-Eleches (2011) used an RD design to examine a Romanian government programme providing home computers to poor children, finding higher cognitive skills and computer skills one year after distribution but lower school grades.

teaching practices – that matters most for student achievement have dogged researchers consistently. Past literature on teacher quality has adopted one of two approaches. In the first, an educational production function links measurable teacher characteristics to pupil achievement, controlling for student characteristics.<sup>66</sup> A second approach calculates teacher quality as a teacher fixed effect to see the qualities of teachers that consistently see high achievement growth for their pupils<sup>67</sup> – these effects give an estimate of which characteristics of teachers matter.

The consensus from a wide array of studies is that standard teacher characteristics such as certification, training and experience do not matter to pupil achievement (Hanushek and Rivkin, 2006). As *résumé characteristics* often underpin teacher compensation policies, these findings are controversial and widely debated.<sup>68</sup> In contrast, evidence on teacher effectiveness seems to suggest it is teaching practices that matter. Practices can include regularity in checking homework, teachers' attitudes towards children and perceptions of their schools (Aslam and Kingdon, 2011; Singh and Sarkar, 2012).

### Contract teachers and remedial education: controversial but effective

Contract teachers have been an increasingly used intervention by resource-constrained governments in large parts of Africa, South Asia and Latin America to try to address rising student numbers. The use of these locally hired teachers on fixed-term renewable contracts is controversial not only because the teachers are generally not professionally trained but also because they are paid much lower salaries than regular civil service teachers.

There is a growing body of evidence on the effectiveness of contract teachers. This includes Muralidharan and Sundararaman (2011), who find in a randomised evaluation in the Indian state of Andhra Pradesh that, after two years, students in schools with an extra contract teacher performed 0.15 and 0.13 standard deviations higher in maths and language tests, respectively. This effect may be via their attendance: contract teachers were significantly less likely to be absent from school than civil service teachers, at 16% vs. 27%, respectively. Contract teachers therefore appear to be more effective in improving student learning than regular civil service teachers, who are more qualified, better trained and paid five times higher salaries.<sup>69</sup>

In addition, evidence has been found for the use of remedial teachers to assist students in the learning process. Banerjee et al. (2007) evaluate a low-cost intervention by Pratham providing *balsakhis* ('the child's friend') – usually young women recruited from the local community with secondary-level education – to government schools to work with children in Grades 3 and 4 and identified as falling behind their peers. The instructor meets with a group of approximately 15-20 children in a class for 2 hours a day during school hours focusing on basic numeracy and literacy skills the children should have learned in Grades 1 and 2. The programme increased average test scores in the treatment schools by 0.14 standard deviations in the first year and 0.28 in the second. Weaker students, who were the primary target of the programme, gained the most.

### Teacher remuneration and performance pay: a mixed bag of evidence

Teacher salary structures can affect teacher effort and student outcomes powerfully. The absolute level of teacher pay across countries is not necessarily linked to student

<sup>66</sup> The methodologies adopted in this approach vary, from IV approaches (Hoxby, 1996; Kingdon and Teal, 2007; Sprietsma and Waltenberg, 2005) to panel data studies (Clotfelter et al., 2006; Hanushek, 2005) to randomised experiment studies (Glewwe and Kremer, 2006; Lavy, 2002).

<sup>67</sup> A number of studies have used this approach (Aarons et al., 2003; Hanushek et al., 2005; Rivkin et al., 2005; and Rockoff, 2004).

<sup>68</sup> Such findings are also reported for India in Kingdon and Teal (2010) and Singh and Sarkar (2012), and for Pakistan in Aslam and Kingdon (2011).

<sup>69</sup> This is also a finding of Atherton and Kingdon (2010), who use school fixed effects with Indian schools data to assess contract teachers.

performance. Hanushek (2003), in his review of production function studies, noted that 'there is very weak support for the notion that simply providing higher teacher salaries or greater overall spending will lead to improved student performance'. However, comparing within one country over time, Menezes-Filho and Pazello (2007), looking at a 1998 reform to teachers' wages in Brazil, found the reform raised the relative wages of public school teachers and that this effect improved student performance. They found this effect owed to the attraction of better teachers into the profession.<sup>70</sup>

### **Box 12: Evidence from the developed world on performance-related pay**

In recent years, many countries have moved towards performance-related pay (PRP) – linking teacher pay to student outcomes. For the US and the UK, several studies have shown improvements in student achievement as a result of PRP (Atkinson et al., 2004; Figlio and Kenny, 2007); experimental evidence from Israel and Mexico has found similar results (Lavy, 2002; Lopez-Acevedo, 2004). Woessmann (2011) reviewed evidence from 28 OECD countries, in which 13 countries use PRP, finding higher scores on maths and reading of 0.25 standard deviations where PRP was used. However, opponents of PRP policies state that they could nullify multidimensional elements of teaching such as creativity and curiosity (Kremer and Holla, 2008).

Evidence shows that, on measures of student achievement, PRP can also be effective in developing country contexts. Kingdon and Teal (2010) find that private schools using PRP in Uttar Pradesh saw student achievement improve, arguing this is most likely because higher wages motivate higher teacher effort rather than because of the recruitment of better-quality teachers.<sup>71</sup> Other evidence for India also finds significant links between PRP and student performance.<sup>72</sup>

The link between PRP and teacher effort may also owe to greater teacher attendance. Duflo et al. (2012) assess a PRP programme run by an NGO, Seva Mandir, in rural villages of Rajasthan, specifically aiming to increase teacher attendance. Here, a student would take a picture of the teacher and other students at the start and close of each school day. Each teacher received Rs) 500 if they attended fewer than 10 days in a given month, and Rs 50 for any additional day (up to a maximum of 25 or 26 days depending on the month).<sup>73</sup> Absenteeism by teachers fell by 21 percentage points relative to the control group, and children's test scores increased by 0.17 standard deviations.

## 5.5 Supply-side interventions: school organisation

### **Class sizes: mixed messages from a variety of contexts**

Class size is a key policy issue at the heart of school organisation, which, given cost implications, is also controversial. Meta-analyses, such as those by Hanushek (2003, 2005), find low evidence of links between pupil-teacher ratios or class sizes and educational outcomes. Krueger (2003) objects to this finding by arguing that many of the studies included in such meta-analyses are of low quality and unable to control for the endogeneity of the class size variable. Krueger argues that, if only higher-quality

<sup>70</sup> Similar findings are made in Aslam and Kingdon (2011).

<sup>71</sup> Higher wages are available as effort-motivating devices only when there is a credible threat of losing a well-paying job if the employee is found to be shirking (applying low effort). A credible threat of this kind exists only in the private school sector and not in the government school sector, where permanent contracts result in little chance of dismissal.

<sup>72</sup> Muralidharan and Sundararaman (2009) provide experimental evidence from a randomised evaluation in Andhra Pradesh in India and show that, after two years, students in schools with PRP performed significantly better than those without by 0.28 and 0.16 standard deviations in maths and language tests, respectively. Other evidence for performance pay comes from Glewwe et al. (2010); Muralidharan and Sundararaman (2011) in Andhra Pradesh found students in intervention schools saw increases of 0.27 and 0.17 standard deviations in math and language tests, respectively.

<sup>73</sup> In comparison schools, teachers were paid a fixed rate for the month (Rs 1,000).

studies are used, it is possible to show a strong positive effect of class size reductions on student performance.

The one randomised experiment on class sizes comes from the US – the Student/Teacher Achievement Ratio (STAR), a four-year longitudinal class size study, funded by the Tennessee General Assembly, conducted by the State Department of Education. Students in kindergarten in 79 schools were randomly assigned to either small classes (13-17 students per teacher), regular classes (22-25 students per teacher) or regular-with-aide classes (22-25 students with a full-time teacher's aide). Students attending smaller classes obtained significantly higher test scores immediately after the experiment but soon thereafter the effect approximately halved, although it remained significant even 10 years after they had left Grade 4 (Krueger, 1999).<sup>74</sup> However, a study by Altinok and Kingdon (2009) using TIMSS data on a sample of 45 developed, transition and developing countries confirms Hanushek's pessimistic conclusion that class size does not have a systematic and substantial effect on student learning. The authors conclude that class size reductions may not be cost-effective interventions for improved learning in developed, developing or transition countries.

### **Box 13: The length of the school day influences learning outcomes**

Another key policy decision in terms of the organisation of schooling and education is how long the school day is. García et al. (2012) use data from Colombia to examine the effects of a change from half-day to full-day schooling on student outcomes. Full-day schooling was found to reduce early school dropout by 1 to 2 percentage points, and grade repetition by 2 to 5 percentage points. This supports evidence from Bellei (2009) for a full-day programme in Chile, with an effect size on language achievement of 0.05-0.07 standard deviations; and from Cerdan-Infantes and Vermeersch (2007) for the lengthening of the school day in Uruguay evaluated using propensity score matching, with test scores up per year of participation by 0.07 standard deviations in mathematics and 0.04 in language.

### **Tracking (setting/streaming): some strong RCT evidence that it works**

Poor learning performance in developing countries has sometimes been put down to a bias towards highly performing students. Students below the level expected to achieve gateway qualifications may not therefore get the attention in class they deserve (Duflo and Banerjee, 2011).<sup>75</sup> Duflo et al. (2010) find in a randomised experiment with 121 primary schools in Kenya that tracking, that is placing students in different classes based on prior achievement streams, benefits lower-achieving pupils by allowing teachers to teach at their level. The authors also noted additional effects: teachers' attendance, for example, was 9.6 percentage points higher in tracking schools, although contract teachers attended more than civil service teachers, and were in class and teaching 74% of the time, versus 45% for the average civil service teacher.

This evidence suggests tracking can directly drive teacher effort, but only at the higher end. Duflo et al. (2010) found contract teachers' absence rate was unaffected by tracking, but civil service teachers were 11 percentage points more likely to be in class and teaching when they were assigned to the top section in tracking schools than when

<sup>74</sup> Angrist and Lavy's (1999) high-quality study, for example, does find significant performance improvements with class size reductions in Israel for Grades 4 and 5, although not for Grade 3. Similarly, Case and Deaton's (1999) analysis of class size reductions during the Apartheid era in South Africa constitutes another exemplary empirical study. The fact that black parents were unable to choose their children's school and school resource allocation was therefore (arguably) exogenous allows for robust estimates of class size to be estimated. On the basis of aggregated data at the district level, reductions in class size were found to have positive effects on district-level enrolment, literacy and numeracy tests, and years of completed schooling.

<sup>75</sup> Teacher bias can be down to ethnicity and, in the Indian context, caste, as shown by Hanna and Linden (2009). They find that teachers give exams that are assigned to be lower caste scores that are about 0.03 to 0.09 standard deviations lower than exams that are assigned to be high caste, with the discrimination highest among low-caste teachers.

assigned to non-tracking schools; if assigned to the bottom section, they were about as likely to be teaching as counterparts in non-tracking schools. After 18 months, the point estimates suggested the average score of a student in a tracking school was 0.14 standard deviations higher than that of a student in a non-tracking school.

## 5.6 Demand-side interventions: the 'nudge'

It is possible to view the supply and demand relationship in education as an iterative one, in which improved quantity and quality of what is supplied elicit a demand response. Demand-side interventions therefore have quite a wide typology, including in health, as discussed above, which can increase the ability of children to go to school, as well as a number of interventions that can be classified as a 'nudge'; these include the likes of school feeding programmes as well as cash transfers. The simplest nudge is the provision of information; Nguyen (2008) found that simply providing parents with information on returns to education improved tests scores by 0.2 standard deviations, with attendance 3.5 percentage points higher.<sup>76</sup>

### School feeding: generally strong evidence, with some mixed findings

The provision of food at school and during the school day again has characteristics of a supply and of a demand intervention – for the latter it could incentivise greater attendance; for the former it could improve performance once there. While several studies have evaluated the impact of school feeding programmes, in terms of their effect on both participation decisions and learning outcomes, the evidence on impact is not always conclusive:

- **Positive effect:** Meng and Ryan (2003) evaluate the Bangladeshi Food for Education Programme, estimating increased school participation rates of 20-30% and educational attainment increases of 0.5 to 2 years.
- **Positive effect:** Vermeersch and Kremer (2005) evaluate a randomised intervention providing school meals to preschools in Kenya, finding that school participation increased by 30%.
- **Positive effect:** Kazianga et al. (2009) use a randomised trial to assess one school lunch intervention, and another with take-home rations conditional on attendance. Both programmes increased girls' enrolment by 5 to 6 percentage points, although there is no observable significant impact on test performance.
- **No effect:** McEwan (2013a) evaluates the impact of Chile's school feeding programme using an RD design and finds no evidence that additional calories affect school enrolment and attendance.
- **No effect:** Bутtenheim et al. (2011) evaluated school feeding programmes in Lao PDR and found minimal evidence of increased enrolment or improved children's nutritional status.

### Cash transfers

The most high-profile demand-side intervention in recent years has been the provision of cash transfers to families, aimed at reducing the direct costs for parents of schooling (see Kremer et al., 2004; Schady and Filmer, 2006; Sparrow, 2007). The cash transfer idea came out of a hugely innovative programme in Mexico, namely, the Programa de Educación, Salud y Alimentación (Education, Health and Nutrition Programme) – Progresá, now renamed Oportunidades. Progresá also pioneered the RCT by randomly allocating among an initial group of localities. The programme provides cash grants,

---

<sup>76</sup> Jenson (2010a) makes a similar finding for the Dominican Republic, and Jenson (2010b) for India, where, following a business process outsourcing recruiting campaign, three years later girls aged five to eleven years old were 5% more likely to be enrolled than those in other villages.

distributed to women, conditional on children's school attendance and preventative health measures. The size of the grants were relatively large: the grant a mother would receive if her daughter were enrolled in Grade 9 would amount to 255 pesos per month (approximately \$23 at the time), or 44% of the typical male day labourer's wage in these rural communities, and roughly two-thirds of what a child this age earned if working full time.

Hanushek (2008) highlights five *high-quality studies* on cash transfers, all of which show significant benefits. This includes two evaluations of Progresa. Schultz (2004a) found particularly large effects of Progresa for secondary education, with an average enrolment effect of 9.2 percentage points for girls and 6.2 percentage points for boys. Todd and Wolpin (2006) found it increased 12-15-year-old girls' attendance by 10% and 12-15-year-old boys' attendance by 3%. Its success led to replication elsewhere, leading to similar programmes in Colombia, Nicaragua and Brazil, all with significant impacts on school participation.<sup>77</sup>

#### **Box 14: Cash transfers also effective when *unconditional* and when *labelled***

Despite the strong evidence on the effectiveness of conditional cash transfers (CCTs), the *conditionality* element has been brought into question by recent experiments in Malawi and Morocco. Baird et al. (2009a, 2010) evaluate a cash transfer programme in Malawi, finding the dropout rate among those in school at baseline decreased from 11% to 6%. But the use of unconditional cash transfers (UCTs) also had a strong impact, although around half as large as that of the CCTs.<sup>78</sup> Benhassine et al. (2013) looked at a large randomised experiment in Morocco to estimate an alternative programme, a 'labelled cash transfer' (LCT): a small cash transfer<sup>79</sup> made to fathers of school-aged children in poor rural communities, not conditional on school attendance but explicitly labelled as an education support programme. They found gains of over 7 percentage points in school participation and 11% of a standard deviation improvement on the ASER arithmetic test. Adding conditionality made no difference. They speculate that the CCT may put off parents owing to its complexity. In addition, if it is felt that less than four absences a month is not going to be possible, they may either not enrol or give up under a CCT, but continue under the LCT.

## 5.7 Demand-side interventions: private vs. public

There is a large and growing literature and debate over the relative merits of private and public education. As shown in Chapter 4, private sector provision is significant in many countries. In addition, in middle-income countries a large market for private tutoring has arisen.<sup>80</sup> Research has focused on the relative quality of public vs. private and the possible reasons for any differences found. In particular, when parents go private, they are more actively making their choice to educate and may therefore scrutinise quality to

<sup>77</sup> Evaluations also cited as high quality by Hanushek (2008) include Attanasio et al. (2006) on Colombia's *Acción* programme, with a 5-7% increase in school participation for 14-17 year olds; Maluccio and Flores (2005) on a similar programme in Nicaragua; and Cardoso and Souza (2004) for Brazil's Bolsa Escola, with highly significant effects on school attendance.

<sup>78</sup> Baird et al. (2009b) also find that the probability of getting married and becoming pregnant declined by more than 40% and 30%, respectively.

<sup>79</sup> The average annual transfer per household was about 5% of annual expenditures, compared with 20% in the Progresa programme. Filmer and Schady (2009) look at how large a CCT should be using evidence from a programme in Cambodia, finding diminishing marginal returns to its size. The \$45 transfer accounts for approximately 2% of the consumption of the median recipient household in Cambodia, while the comparable value is 22% for recipients of Oportunidades and 6% for recipients of the Bolsa Família programme in Brazil and the Bono de Desarrollo Humano programme in Ecuador.

<sup>80</sup> Dang (2007) notes that a large 'shadow' education system of private tutoring exists alongside the Vietnamese education system. Increasing spending on private tutoring from VND 0 to VND 20,000 increases the probability of having a good and excellent academic ranking by 0.05. In South Korea, Kim and Lee (2004) find parents spent 2.9% of the nation's GDP on private tutoring for primary and secondary students.



a higher degree and monitor progress more closely. The greater competition resulting from the exercise of choice should also in theory lead schools to raise standards.

### Higher performance, lower cost

The key difference between public and private schools, particularly low-fee private schools, is likely to be via teachers. For example, low-fee private school teachers tend to have less experience than government teachers but are cheaper to employ (see Chapter 4). In Punjab, Pakistan, the proportion of teachers who reported having more than 20 years of experience was 43% in government schools but 5% in private schools (Aslam and Kingdon, 2011). In Andhra Pradesh, India, teachers in government schools have more than seven years of experience, on average, whereas those in private schools have fewer than five years (Singh and Sarkar, 2012). Despite this, the performance of students in private schools appears to be better. For example, in Pakistan the average child in a private school performed better than the level required to be in the top one-third of children in government schools, after wealth, age, gender and parental education were all taken into account (Andrabi et al., 2007).

Evidence of better learning outcomes in the private sector, even when controlling for other factors, may also come from school organisation factors such as class sizes and the ability to fire teachers. In 23 private schools across four districts in Nairobi, for example, there are 15 students per teacher, compared with 80 in government schools (Stern and Heyneman, 2013). In Patna, in Bihar state, India, there are 22 students for every private school teacher, compared with 42 for every government school teacher (Ramgaraju et al., 2012). In India, private school pupils receive three to four times as much teacher contact time as pupils in government schools (Muralidharan and Kremer, 2009). Private school teachers are also thought to work under conditions of greater accountability. A nationally representative study in India found that only one head teacher in 3,000 government schools reported dismissing a teacher for repeated absence. By contrast, 35 private school head teachers, out of 600 surveyed, reported having dismissed teachers for this reason (ibid.).

### Vouchers

A key policy for promoting use of private schools is through directly subsidising their use via voucher privatisation. Vouchers are provided that can be redeemed at private schools, giving the benefits of parental choice and private sector quality, but retaining public sector subsidies to education. Advocates argue that even the students who remain in public schools benefit because school choice induces public schools to improve in order to retain pupils (Hoxby, 2000).

Evidence for vouchers is mixed. Bitler et al. (2013) find no evidence of improvement from a New York City voucher scheme. Hsieh and Urquiola (2003) find that more than 1,000 new private schools followed Chile's nationwide voucher scheme in 1981, but there is no evidence that increased choice improved outcomes as measured by average test scores, repetition rates and years of schooling. The programme led to increased sorting, as the 'best' public school students left for the private sector. Other evidence is more positive;<sup>81</sup> Böhlmark and Lindahl (2012) assess Swedish 1992 reforms and find that increased school competition raised educational outcomes. Angrist et al. (2002, 2006) evaluate lottery distribution of vouchers in Colombia,<sup>82</sup> finding that three years after the lotteries, winners were about 10 percentage points more likely to have completed Grade 8 and 5 to 7 percentage points more likely to graduate from high

---

<sup>81</sup> This includes Angrist et al. (2002) and Rouse (1998).

<sup>82</sup> Under the Programa de Ampliación de Cobertura de la Educación Secundaria, Colombia awarded around 125,000 vouchers between 1991 and 1997, partly covering the costs of private school for students from poor neighbourhoods. Vouchers were renewable every year through Grade 11, contingent on satisfactory academic performance (grade promotion).

school (secondary education) and scored 0.2 standard deviations higher on achievement tests. The effects were larger for girls than for boys.

## 6 Aid, finance and education

### Key messages

- **The large number of institutions providing 'aid' to developing countries makes the financing of education very complex.**
- **Many countries in the SSA region have a high amount of education spending from development aid, over a quarter for 15 countries.**
- **Evidence from public expenditure tracking surveys (PETS) in the education sector has shown that devolved government budgets often do not get to the front line of education service delivery.**
- **This is linked to a number of political economy issues including the fragmentation of education delivery exacerbated by multiple donors, as well as clientelism, patronage and corruption.**
- **Analysis of the costs and benefits, or VfM, of interventions using data from RCTs or elsewhere must take account that results experienced may be specific to the institution that achieved them, the scale of intervention and the specific characteristics of the locality.**
- **This makes successful interventions in education more complex to design, and evidence suggests the simple scale-up of successful interventions operated on a small-scale by NGOs may not work at a national level.**

### 6.1 Multiple players in education in developing countries

Previous chapters have set out the advantages, both economic and non-economic, of improving education for a country as a whole and for its citizens. While benefits appear to be very high (see Chapters 2 and 3), current performance levels in education in terms of rates of enrolment and learning outcomes remain a concern, with 61 million children of primary school age out of school (see Chapter 4), and very low learning outcomes even for children who get into and through the school system (see Section 4.4).

Chapter 5 set out a wide range of evidence for a typology of demand- and supply-side education policies and interventions to improve this situation. This might appear to be a 'pick and mix' of best practice that policymakers and development practitioners simply need to choose from. However, as set out in this final chapter, policymaking takes place in the context of resource constraints and a complex political economy with a range of players, whose interests and incentives shape the design, formulation and implementation of policies. It is inherently not possible to *intervene* outside of this complex system, so interventions must be intelligently designed in a way that understands and adapts to the multiple linkages and players in the education of developing countries.

#### The players in education in developing countries

There is a complex web of interactions for financing and providing education in developing countries. Public expenditure can be funded by *tax receipts*, and indirectly by *budget support* and by *debt relief*. The education budget can also be supplemented by donors with explicitly allocated *on-budget aid*. In addition, the private sector and NGOs also have a role in financing, with *off-budget aid* again playing a role. Last but not least, households themselves make a significant contribution to the total expenditure on education. Figure 6 shows this complex web of finance.

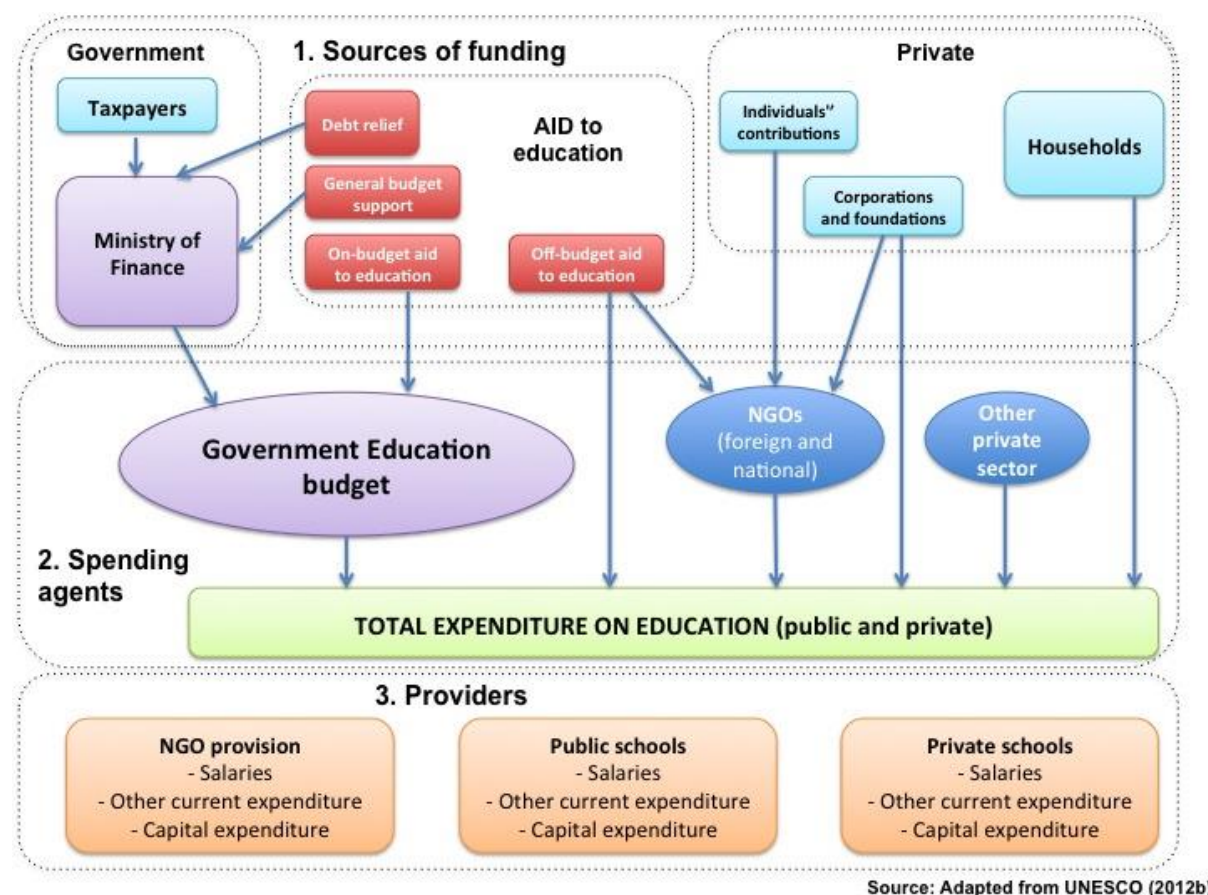
**Figure 6: Sources of finance and key players in education in developing countries**

## 6.2 Financing for education, where does it come from?

### Public spending on education

The predominant source of financing for education in developed countries comes from the government, via tax revenue. For developing countries, tax revenue is a smaller source, mainly because of ineffective tax collection, and is supplemented by donor funding. Figure 7 shows how much tax revenue is dedicated to education expenditure and how much tax revenues are as a portion of GDP for a range of low- and middle-income countries. This shows that there are many countries for which tax revenues are very low as a proportion of GDP, although they differ in how much they allocate to education. Countries such as Ethiopia allocate over 25% of their pot to education, compared with less than 10% in Pakistan. Other countries have much larger tax revenues as a share of GDP, such as Angola and Namibia, which contrast with a weak and strong focus on education as a share of the tax expenditure, respectively.

#### **Box 15: Countries not meeting targets for tax revenue or education expenditure**

It is increasingly argued that the escape from aid dependency and from poverty more broadly requires effective tax collection in developing countries; for example, it has been estimated that countries need to raise 20% of their GDP in taxes to achieve the UN MDGs (IMF et al., 2011). For education, 37 countries get less than 20% of GDP in tax revenue and spend less than 20% of government expenditure on education. There is clearly a long way to go, although recent progress is mostly in the right direction, as shown in Figure A6 in Annex A: the proportion of gross national product going towards education increased for most low- and middle-income countries in the 1999-2011 period.

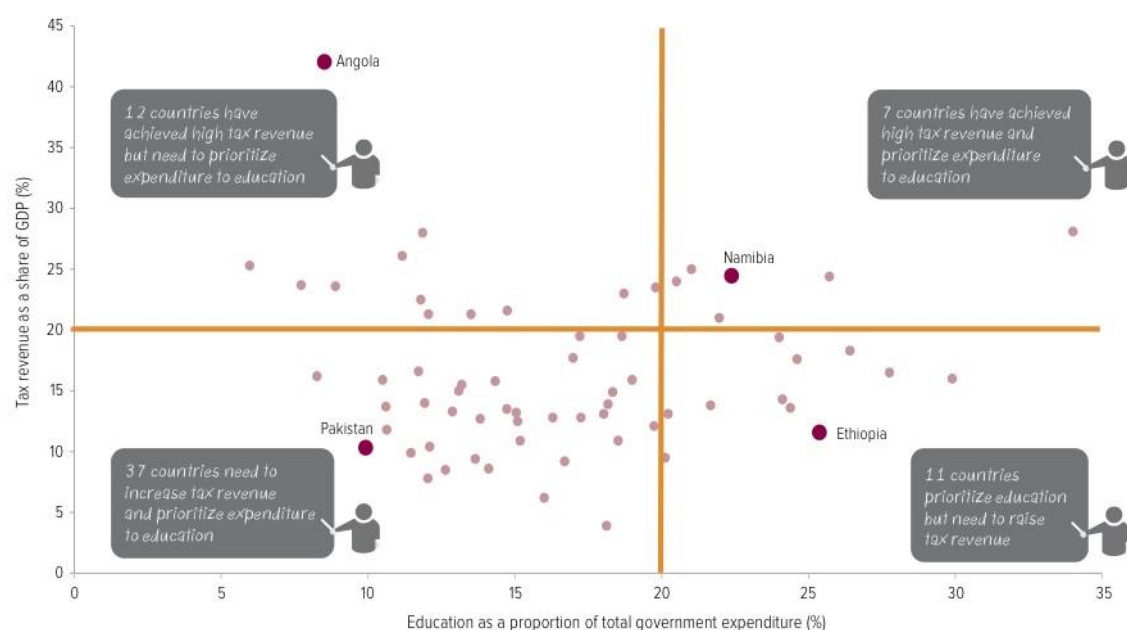
**Figure 7: Low- and middle-income countries tax revenue and education spend**

Source: UNESCO (2014).

### Official development assistance on education

The importance of aid or official development assistance (ODA) in funding education in developing countries is huge, although variable. As shown in Figure 8, this is as high as around three-quarters of total education expenditure for Liberia, around half for Rwanda, Mali and Zambia, a third for Burkina Faso, Benin and Burundi and a quarter in Senegal, Niger and Uganda (for 2008). There is also a large range of expenditures from ODA on education as measured by purchasing power parity (PPP) US dollar expenditure, with Nigeria getting just \$2 per capita in 2008, compared with \$159 in São Tomé and Príncipe. This seems perverse when compared with the numbers of out-of-school girls as shown in Chapter 4, with Nigeria arguably the worst-performing country in the world. But it is a function of the operations of donors, who may not prioritise expenditure by population size.

#### Box 16: Total aid to education reduced as a result of international financial crisis

Total aid to education is estimated at \$13.4 billion in 2011, with \$5.8 billion to basic education, \$2.2 billion to secondary education and \$5.4 billion to post-secondary education (UNESCO, 2014). This is a reduction on recent years, lower than the \$14.4 billion distributed in 2009 and 2010. The reduction is reflective of broader decreases in aid expenditure by a range of developed countries, with 24 donors reducing aid to basic education in 2010 and 2011, likely linked to the recent international financial crisis. The US' contributions to basic education were cut by so much that it is for the first time in second place to the UK in aid to education (ibid.) DFID spent £805 million or 8.2% of its budget on education in the past year.<sup>83</sup> The Netherlands meanwhile decided in 2011 to phase out education programmes that did not contribute directly to its foreign policy priorities, subsequently cutting aid to education by one third (ibid.).

<sup>83</sup> Project budgets for each sector (FY13/14): <http://devtracker.dfid.gov.uk/>

**Figure 8: ODA to education as a ratio of total public education expenditure, and in per capita PPP US dollars by country and region, 2008**

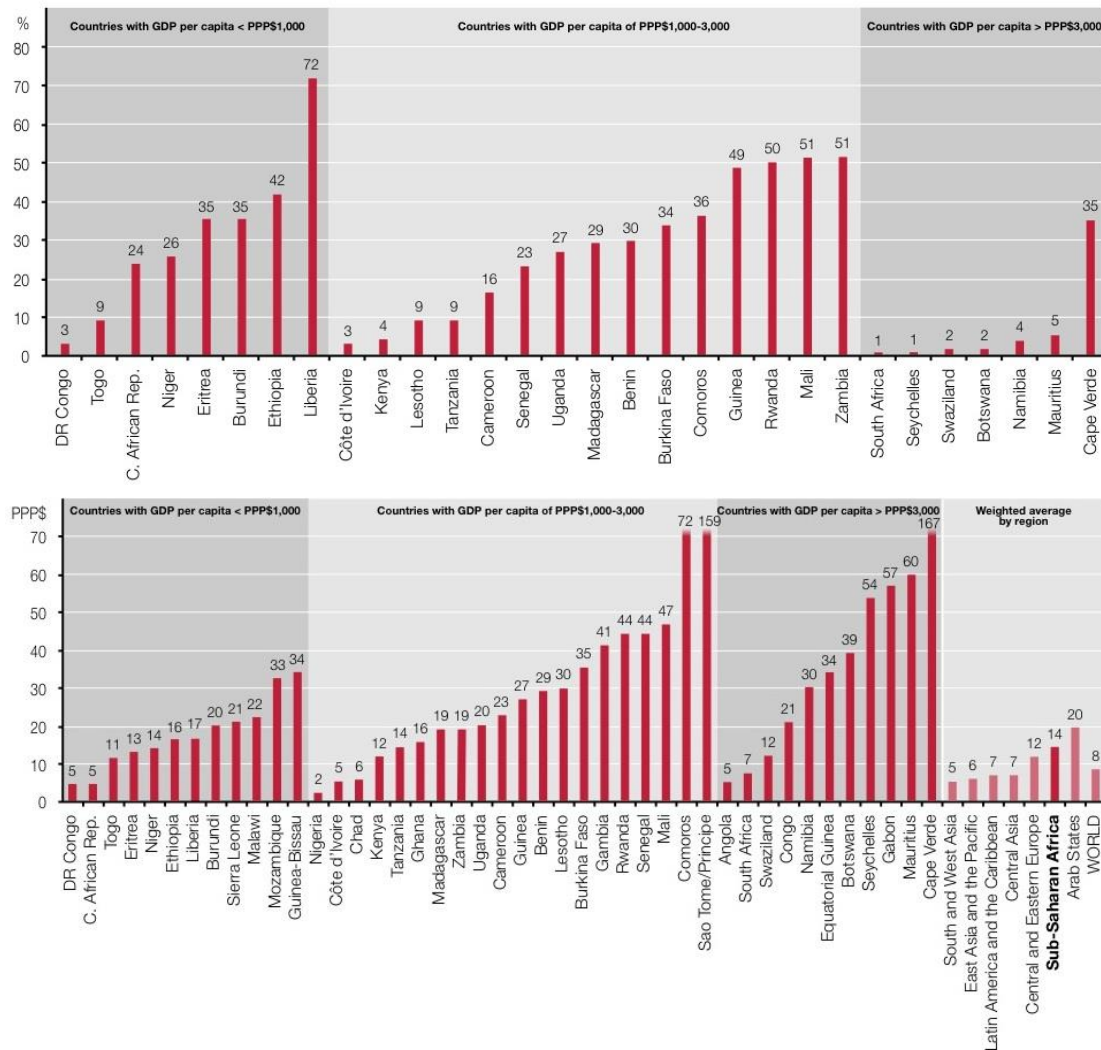

Source: UNESCO (2011).

### Untangling aid in education expenditure

Despite the apparently clear figures represented above, it is quite a significant challenge to untangle the amount of aid in the education expenditure of developing countries, as set out in UNESCO (2012b). This is because donors fund education through government budgets, but also outside them and through different agents, such as NGOs. The first challenge arises because aid to education reported to the OECD's Creditor Reporting System (CRS), the principal source of aid data, includes large sums that do not reach recipient countries. For example, ODA in education reported by Development Assistance Committee (DAC) donors<sup>84</sup> includes 'imputed student costs', or the costs incurred by donor countries' higher education institutions when they receive students from developing countries, as well as scholarships. In 2010, *one quarter of all direct aid to education was imputed student costs and scholarships*, around 80% of which comes from France, Germany and Japan (ibid.). Using ODA to education in calculations risks vastly overstating foreign contributions to in-country spending, especially in countries where these three donors are important contributors.

<sup>84</sup> The DAC is a forum for selected OECD member states to discuss issues surrounding aid, with 29 members.

In many developing countries, donors fund the Ministry of Finance directly through general budget support (GBS), aid that is not earmarked to a specific sector and can be spent according to national priorities. The importance of GBS varies greatly from country to country and from year to year, but it can be significant. In 2010, 17% of all aid received by Malawi was GBS, and 20% in Mozambique (UNESCO, 2012b). To illustrate the complexity of untangling aid in education spending, Figure 9 shows an example of public funding of education in Rwanda, a country that has made significant progress towards education goals but has relied heavily on aid to do so. This shows that three-quarters of the education budget came from the government through the Ministry of Finance, with donors funding the other quarter. In addition, donors funded around \$30 million-worth of education projects that are not included in the budget. Further, 35% of the government's total budget originally came from GBS aid. By bringing these elements together UNESCO (2012b) estimates that 54% of total public funding of education came from donor sources in 2009/10, while the government of Rwanda contributed 46%.<sup>85</sup>

**Figure 9: Disentangling public funding of education in Rwanda for 2009/2010**

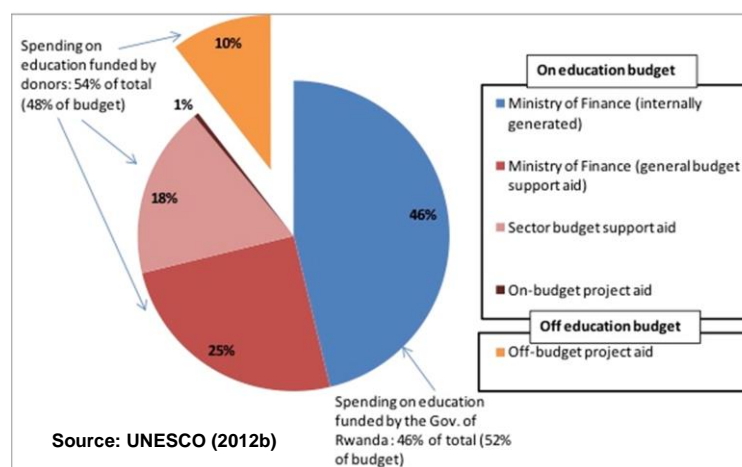

Source: UNESCO (2012b)

### 6.3 Fungibility of aid in education

#### Does the money get to the schools?

When education is financed, particularly by donor aid, the obvious question that follows is whether the money is well spent, or whether it is diverted by wastage or corruption. It is also commonly noted that, while education expenditure in certain countries has increased several-fold over the past few decades, this has not always translated into improved learning outcomes. This may owe partly to shortcomings in states' capacity and in administration and delivery systems, which hinder the achievement of education outcomes. The PAISA report in India (2012) examined grants made to schools under the government of India's Sarva Shiksha Abhiyan programme, the primary vehicle for implementing the Right to Education Act (2009) in the country. The report has extensively analysed data on the programme's expenditures to provide an attempt at following the money to the school level. In 2011-2012, 87% of schools reported receiving their School Maintenance Grant as compared with 84% the previous year. Despite improvement, over one in ten schools do not receive the grants they are due.

In a survey of seven African countries<sup>86</sup> undertaken through the Africa Education Watch programme, which ran from 2007 to 2010 with a series of surveys of households, schools and local government educational officials, 85% of schools surveyed across all countries had either deficient accounting systems or none at all (Antonowicz et al., 2010). Additionally, the unpredictability of when and how much funding or resources would reach schools undermined both planning and any meaningful financial oversight,

<sup>85</sup> Debt relief presents a further difficulty. Initiatives such as the Heavily Indebted Poor Countries (HIPC) Initiative or the Multilateral Debt Relief Initiative (MDRI) mean governments spend less on debt service, which releases funds for other spending.

<sup>86</sup> Ghana, Madagascar, Morocco, Niger, Senegal, Sierra Leone and Uganda.

with, for example, only about half of households feeling that school management committee decision making was transparent (ibid.). The evidence suggests systems were not in place to adequately monitor finance for schools.

### Public expenditure tracking surveys: the experience of Uganda and Tanzania

This evidence has been supplemented in recent years by a number of public expenditure tracking surveys (PETS), which more or less do what they say – look at how much of allocated expenditure is received at each chain of the education system – ‘following the money’. In an interesting comparison of Uganda and Tanzania, Sundet (2008) shows how PETS can have very differing impacts. This includes the PETS methodology developed for Uganda in the 1990s, at a time when ‘leakages’ of funds intended for primary schools were very high. The Uganda PETS has become one of the most frequently cited success stories in the anti-corruption literature. By comparing funds that had been transferred from central government with the receipts at the schools surveyed, a World Bank team found that, in 1995, only 26% of the cash intended for the primary schools made it to the schools (Ablo and Reinikka, 1998). Most of the schools received no funds at all, and it was also found that many schools were not even aware that they were entitled to such a grant.

After the findings of the survey became known, the Ugandan government conducted a public information campaign, with the Ministries of Local Government and Finance publishing data on the monthly transfers of the capitation grants in national and local-language newspapers. After 1997, the Ministry of Education also required district headquarters and schools to publicly post notices informing communities when funds were received. Subsequently, a follow-up PETS Survey by the World Bank in 2002 found a dramatic improvement, with more than 80% of the funds transferred to the schools from central government now received (Reinikka and Svensson, 2002). This achievement of reducing leakage from 74% to less than 20% is often attributed to the PETS methodology (Sundet, 2008). However, the finding has been heavily criticised for ignoring a number of other policies undertaken at the same time as the information campaign (Hubbard, 2007).

In contrast, the Tanzanian case study offers a less successful example of the PETS methodology. Tanzania was one of the first countries after Uganda to apply the methodology, with the country’s first PETS conducted in 1999. The survey tracked non-wage recurrent expenditure in the education and health sectors. The survey found that only 43% of education funds were transferred to schools, and this was confirmed by a second survey in 2001 (Sundet, 2007). However, the findings did not lead to the policy debate they did in Uganda. Even today, neither PETS survey has been fully published in the country. In 2004, Tanzania conducted a much larger and more ambitious PETS. The survey tracked the finances of the Primary Education Development Project and was based on a large, representative sample of 210 schools from 21 districts (REPOA, 2004). It indicated leakages in the range of 40%. The Tanzanian government reaction to the findings was, however, to question the methodology. The Ministry of Finance immediately submitted a rebuttal, with a list of objections to the methodology used (Sundet, 2008).

The experience of Uganda and Tanzania show that *fungibility* of finance to education including aid expenditure can be very poor, with significant ‘leakage’. In addition, even when the issue is identified, governments can be reluctant to tackle it. This is a prime example of implementation failures caused by the political economy of education rather than specific policies and interventions.

## 6.4 Political economy of aid and education

### The influence of donors may disenfranchise developing country bureaucracies

The vagaries of aid expenditure are subject to the whims and political priorities of donor states. Since the 1960s, aid agencies have been proliferating, with most countries



preferring to retain control over their own resources and having offices in countries they often prioritise from a foreign policy perspective. As such, there are now a host of multilateral and bilateral players operating across many sectors, and via mixtures of GBS and project support. This has arguably led to fragmentation of delivery, particularly in social sectors such as education.<sup>87</sup> This means that, in education, there is a large number of parallel budgeting systems, with smaller education projects operating their own budget structures, and donors having concomitantly less incentive to improve the systems of developing country governments' ministries. There is an argument that this disenfranchises state bureaucracies, particularly given that donor-funded projects may also recruit (or 'poach') the best and the brightest of national civil servants (Van de Walle, 2001).

Donors as a whole, though, have put massive emphasis on social sectors such as education, and their influence is most acute in countries' poverty reduction strategy papers (PRSPs), which often prioritise greater spending on education and health (IMF 2012). PRSPs have become the basic instrument for bilateral and multilateral agencies in the design of countries' development strategies (Tarabini and Jacovkis, 2012). Given that debt relief is often conditional on delivery of PRSP objectives, this can be seen to be a significant incentive to increase spending on education.

### Political economy of education within developing countries

Political processes and practices internal to developing countries can also have an impact on the development and implementation of educational policies. In particular, the importance of power relations between teachers, unions and government can influence education outcomes. Kingdon et al. (2014) place the literature around five key themes:

1. Roles and responsibilities;
2. Rent seeking and patronage politics;
3. Decision making and the process of influence;
4. Implementation issues; and
5. Driving forces.

In terms of the first theme, they find that, while a wide variety of stakeholder groups have roles to play, a large empirical literature highlights the strong influence exerted by teacher unions in the shaping of education policies. Teachers' bargaining power, in turn, stems from their ability to influence electoral outcomes and political fortunes, their disruptive capacity to extract economic rents, their extensive geographic presence, their large mobilisation capacity and their ability to finance demonstrations and sustain strikes.<sup>88</sup> They find that rent seeking (by different educational stakeholders) and patronage politics are rife in the educational setups within the public school sector in developing countries.<sup>89</sup>

Kingdon et al. (2014) conclude that clientelism, patronage and corruption are the three most intense political forces that push states to expand access rather than improve quality of education. The study notes the existence of a small quantitative literature examining the role of institutional influence on educational outcomes (Woessmann,

<sup>87</sup> This has also been led by the political need for donors to justify aid expenditure to host country taxpayers, and to demonstrate tangible results. Fears of badly spent aid money has in part led to DFID pledging in 2010/11 to halve its bilateral GBS of £360 million by 2013/2014 (see <http://www.publications.parliament.uk/pa/ld201012/ldselect/ldconaf/278/27810.htm>) and reprioritise towards project aid such as that delivered by the Girls' Education Challenge programme (<https://www.gov.uk/girls-education-challenge>)

<sup>88</sup> See, for instance, Béteille (2009); Carnoy et al. (2007); Eberts and Stone (1987); Hoxby (1996); Kingdon and Muzammil (2008, 2013); Moe (2001, 2006); Pratiche India Trust (2009); Santibáñez and Rabling (2006); and Sharma (2009).

<sup>89</sup> However, Mulkeen (2010) argues that, while teacher unions have been heavily criticised for their advocacy role for better pay and conditions for their members, unions are also responsible for engaging teachers in other activities such as policy analysis and advocacy for improved educational quality and global education campaigns.

2003). It presents evidence that international differences in student performance are considerably related to institutional as opposed to resource-level differences between countries. Thus, the crucial question for education policy is not necessarily that of more resources, but that of creating an institutional system where all involved are provided with incentives to use resources efficiently and to improve student performance.

### Political economy in conflict-affected contexts

The political economy environment of conflict-affected states is, as always, more complex. Novelli et al. (2013) group findings around the three stages of the policy cycle: policy agenda setting, policy formulation and policy implementation. For the first, the review finds that the education sector has been marginalised within international agendas for conflict-affected contexts that prioritise humanitarian aid and security; this forecloses opportunities to address structural social, political and economic inequalities often underpinning conflict, including issues of inequitable educational provision and access. On policy formulation, the study notes a disjunction between generic globally formulated educational agendas and the specific challenges of conflict-affected states, including issues of social justice, economic and political exclusion and cultural repression. For policy implementation, the review finds that the effectiveness of educational interventions is very often undermined by insufficient attention to the cultural, social, religious and political contexts. The study argues for a need to engage national and subnational stakeholders and players into the process to improve outcomes.

In short, development partners need to be fully aware of the political economy context in which they work. The idea that a particular well-evidenced intervention will be the key to educational outcome improvements will not hold unless the barriers of vested interests are taken into account.

## 6.5 Value for money of interventions in education

### Combining cost information and effectiveness information

VfM or cost effectiveness provides a measure of how, *comparatively*, interventions in education achieve results. As discussed above, education systems are complex and have many actors, so cost effectiveness or VfM analysis is likely to require severe simplifications. In addition, evidence from one setting is implicitly being compared with that from others, where the same conditions may not hold. Despite these caveats, Kremer (2012) has brought together evidence on interventions (much of which is presented in Chapter 5) to estimate relative cost effectiveness – see Figure 10. This shows that by far the most cost-effective intervention is the provision of information on education – a demand-side intervention from Madagascar (see Section 3.5, evidence from Nguyen, 2008) – and this is followed by cost-effectiveness evidence from the celebrated RCTs on deworming in Kenya and India (Bobonis and Puri-Sharma, 2006; Miguel and Kremer, 2004) and uniform distribution in Kenya (Kremer and Ngatia, 2009).

### A health warning on extrapolating from RCTs

Bold et al. (2013) provide a clear warning on extrapolating from RCTs. RCTs often measure the impacts of very small and focussed interventions, usually run by NGOs. Such evaluations may therefore provide *internally valid* measures of the causal effect of interventions ('it worked here'), but not necessarily *externally valid* measures ('it will work there'). They look at an RCT of such an intervention that was subsequently scaled up nationally, in Kenya. Evidence from one of the RCTs reported in Chapter 5 (see Section 5.5) from Duflo et al. (2010) on an NGO-managed contract teacher programme in government schools in western Kenya found significant learning impacts.

In 2009, the Kenyan government announced a nationwide contract teacher programme that would eventually employ 18,000 teachers. The government included a randomised experiment within this programme, where implementation was done

in some schools by an NGO and others by government. Bold et al. (2013) find positive and significant effects of the programme only in schools where it was administered by the international NGO. Placing an additional contract teacher in a school where the programme was managed by the NGO increased test scores by roughly 0.18 standard deviations. Treatment effects were significantly smaller and indistinguishable from zero in schools receiving contract teachers from the Ministry of Education.

The reasons cited for the deviation in performance when scaled up may owe to the political economy impacts of the larger programme;<sup>90</sup> in particular, the hiring of 18,000 new contract teachers was likely to provoke organised resistance from the national teachers union. As Bold et al. note, 'While a small number of contract teachers can be employed at wages far below civil service levels, a large cohort of contract teachers becomes politically potent and able to demand civil service protections.' They find

<sup>90</sup> They also found that schools in the government treatment arm received fewer monitoring visits, and teachers experienced longer salary delays, although of these intermediate indicators only salary delays were significantly, negatively correlated with improvements in pupil test performance.

**Figure 10: Cost effectiveness. Estimated additional years of education per \$100 spent**

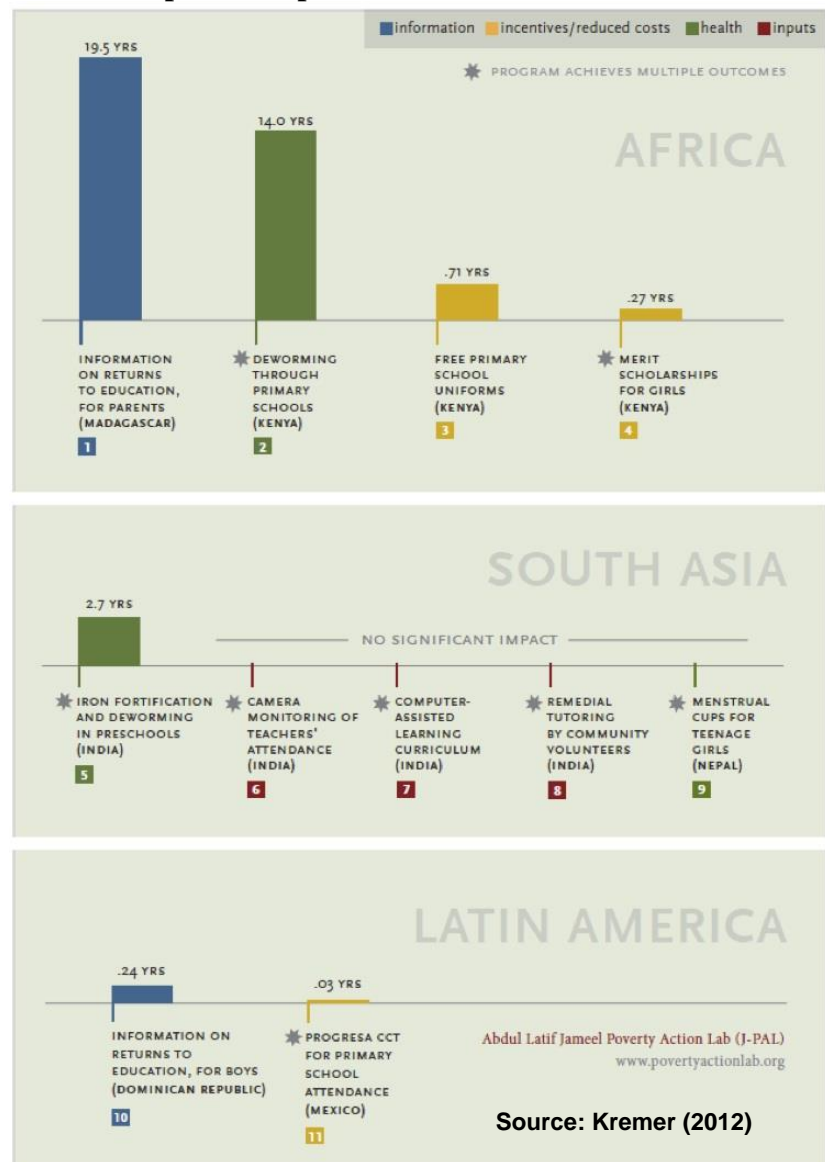

evidence that union actions to demand permanent civil service employment and union wages had a differential effect on teachers employed by the government and the NGO during the evaluation, although neither was formally covered by union collective bargaining.

In conclusion, when a successful intervention is scaled up by a government (or by a donor), implementation constraints and political economy forces may 'interfere' with the ability to lead to successful outcomes. This means in designing policies and interventions the system-wide impacts at scale need to be understood and modelled beforehand.

## References

- Aaronson, D., Barrow, L. and Sander, W. (2003) '[Teachers and Student Achievement in the Chicago Public High Schools](#)'. WP-2002-08. Chicago, IL: Federal Reserve Bank of Chicago.
- Ablo, E. and Reinikka, R. (1998) '[Do Budgets Really Matter? Evidence from Public Spending on Education and Health in Uganda](#)'. Policy Research Working Paper 1926. Washington, DC: World Bank.
- Acemoglu, D. (2007) 'Advanced Economic Growth'. Lecture 1: Introduction, 5 September. <http://economics.mit.edu/files/1489>
- Acosta, P. (2006) '[Labor Supply, School Attendance, and Remittances from International Migration: The Case of El Salvador](#)'. Policy Research Working Paper 3903. Washington, DC: World Bank.
- Aizer, A. and Stroud, L. (2010) '[Education, Knowledge and the Evolution of Disparities in Health](#)'. Working Paper 15840. Cambridge, MA: NBER.
- Akresh, R., Bagby, E., de Walque, D. and Kazianga, H. (2012) '[Child Ability and Household Human Capital Investment Decisions in Burkina Faso](#)'. *Economic Development and Cultural Change* 61(1): 157-186.
- Albouy, V. and Lequien, L. (2009) '[Does Compulsory Education Lower Mortality?](#)' *Journal of Health Economics* 28(1): 155-168.
- Altinok, N. and Kingdon, G. (2009) '[New Evidence on Class-Size Effects: A Pupil Fixed Effects Approach](#)'. Working Paper 2009-16. Oxford: CSAE.
- Andrabi, T., Das, J., Khwaja, A.I., Vishwanath, T. and Zajonc, T. (2007) '[Pakistan Learning and Educational Achievements in Punjab Schools \(LEAPS\): Insights to Inform the Education Policy Debate](#)'. Washington, DC: World Bank.
- Angrist, J. and Lavy, V. (1999) '[Using Maimonides' Rule to Estimate the Effect of Class Size on Scholastic Achievement](#)'. *Quarterly Journal of Economics* 114(2): 533-575.
- Angrist, J. and Lavy, V. (2002) '[New Evidence on Classroom Computers and Pupil Learning](#)'. *The Economic Journal* CXII: 735-765.
- Angrist, J., Bettinger, E., Bloom, E., King, E. and Kremer, M. (2002) '[Vouchers for Private Schooling in Colombia: Evidence from a Randomized Natural Experiment](#)'. *American Economic Review* 92(5): 1535-1559.
- Angrist, J., Bettinger, E. and Kremer M. (2006) '[Long-Term Consequences of Secondary School Vouchers: Evidence from Administrative Records in Colombia](#)'. *American Economic Review* 96: 847-862.
- Antonowicz, L., Lesné, F., Stassen S. and Wood, J. (2010) '[African Education Watch. Good Governance Lessons for Primary Education](#)'. London: Transparency International.
- Appleton, S., Hoddinott, J. and Krishnan, P. (1999) '[The Gender Wage Gap in Three African Countries](#)'. *Economic Development and Cultural Change* 47(2): 289-312.
- Aromolaran, A.B. (2006) '[Estimates of Mincerian Returns to Schooling in Nigeria](#)'. *Oxford Development Studies* 34(2): 265-292.
- Asadullah, M.N. (2012) '[Intergenerational Wealth Mobility in Rural Bangladesh](#)'. *Journal of Development Studies* 48(9): 1193-1208.
- Ashenfelter, O. and Krueger, A.B. (1994) '[Estimates of the Economic Returns to Schooling from a New Sample of Twins](#)'. *American Economic Review* 84(5): 1157-1173.
- Aslam, M. and Kingdon, G. (2011) '[What Can Teachers Do to Raise Pupil Achievement?](#)' *Economics of Education Review* 30(3): 559-574.

- Aslam, M. and Kingdon, G. (2012) '[Parental Education and Child Health—Understanding the Pathways of Impact in Pakistan](#)'. *World Development* 40(10): 2014-2032.
- Aslam, M., Bari, F. and Kingdon, G. (2012) '[Returns to Schooling, Ability and Cognitive Skills in Pakistan](#)'. *Education Economics*. 20(2): 139-173.
- Aslam, M., Kingdon, G. and Rawal, S. (2013) 'Teacher Quality', in World Bank (2013) *Flagship Report on Quality Schooling in South Asia*. Washington, DC: World Bank.
- Atherton, P. and Kingdon, G. (2010) '[The Relative Effectiveness and Costs of Contract and Regular Teachers in India](#)'. Working Paper 2010-15. Oxford: CSAE.
- Atkinson, A, Burgess, S., Croxson, B., Gregg, P., Propper, C., and Wilson, D. (2004) '[Evaluating the Impact of Performance-related Pay for Teachers in England](#)'. Working Paper 04/113. Bristol: Centre for Market and Public Organisation, University of Bristol.
- Attanasio, O., Fitzsimons, E., Gomez, A., Lopez, D., Meghir, C. and Mesnard, A. (2006) '[Child Education and Work Choices in the Presence of a Conditional Cash Transfer Programme in Rural Colombia](#)'. Working Paper 06/01. London: Institute for Fiscal Studies.
- Baird, S., McIntosh, C. and Özler, B. (2009a) '[Designing Cost-Effective Cash Transfer Programs to Boost Schooling among Young Women in Sub-Saharan Africa](#)'. Policy Research Working Paper 5090. Washington, DC: World Bank.
- Baird, S., Chirwa, E., McIntosh, C. and Özler, B. (2009b) '[The Short-Term Impacts of a Schooling Conditional Cash Transfer Program on the Sexual Behavior of Young Women](#)'. Policy Research Working Paper 5089. Washington, DC: World Bank.
- Baird, S., McIntosh, C. and Özler, B. (2010) '[Cash or Condition? Evidence from a Cash Transfer Experiment](#)'. Policy Research Working Paper 5259. Washington, DC: World Bank.
- Banerjee, A.V. and Duflo, E. (2005) '[Growth Theory through the Lens of Development Economics](#)', in P. Aghion and S. Durlauf (ed.) *Handbook of Economic Growth* 1(1): 473-552.
- Banerjee, A.V., Cole, S., Duflo, E. and Linden, L. (2007) '[Remedying Education, Evidence from Two Randomized Experiments in India](#)'. *Quarterly Journal of Economics* 122(3): 1235-1264.
- Barrera, A. (1990) '[The Role of Maternal Schooling and Its Interaction with Public Health Programs in Child Health Production](#)'. *Journal of Development Economics* 32: 69-91.
- Barrera-Osorio, F., Bertrand, M., Linden L. and Perez-Calle, R. (2008) '[Conditional Cash Transfers in Education Design Features, Peer and Sibling Effects Evidence from a Randomized Experiment in Colombia](#)'. Working Paper 13890. Cambridge, MA: NBER.
- Barrera-Osorio, F. and Filmer, D. (2013) '[Incentivizing Schooling for Learning Evidence on the Impact of Alternative Targeting Approaches](#)'. Policy Research Working Paper 6541. Washington, DC: World Bank.
- Barro, R.J. (1991) '[Economic Growth in a Cross Section of Countries](#)'. *Quarterly Journal of Economics* 106(2): 407-443.
- Battaglia, M. and Lebedinski, L. (2013) '[The Curse of Low Aspirations, Remedial Education and Perceived Returns to Education of Roma People](#)'. Bocconi: Bocconi University.
- Becker, G.S. (1964) *Human Capital*. Chicago, IL: University of Chicago Press.
- Behrman, J. and Deolalikar, A. (1988) 'Health and Nutrition', in H. Chenery and T. Srinivasan (eds) *Handbook of Development Economics, Vol. 1*. Amsterdam: North Holland.

- Behrman J. and Wolfe, B. (1984) '[The Socio-Economic Impact of Schooling in a Developing Country](#)'. *Review of Economics and Statistics* 66(2): 296-303.
- Behrman, J., Khan, S., Ross, D. and Sabot, R. (1997) '[School Quality and Cognitive Achievement Production: A Case Study for Rural Pakistan](#)'. *Economics of Education Review* 16(2): 127-142.
- Beine, M., Docquier, F. and Rapoport, H. (2008) '[Brain Drain and Human Capital Formation in Developing Countries: Winners and Losers](#)'. *The Economic Journal*, 118: 631-652.
- Bellei, C. (2009) '[Does Lengthening the School Day Increase Students' Academic Achievement? Results from a Natural Experiment in Chile](#)'. *Economics of Education Review* 28(5): 629-640.
- Benhabib, J. and Spiegel, M. (1994) '[The Role of Human Capital in Economic Development. Evidence from Aggregate Cross-Country Data](#)'. *Journal of Monetary Economics* 34(2): 143-174.
- Benhassine, N., Devoto, F., Duflo, E., Dupas, P. and Pouliquen, V. (2013) '[Turning a Shove into a Nudge? A "Labeled Cash Transfer" for Education](#)'. Working Paper 19227. Cambridge, MA: NBER.
- Bennell, P. (1996) '[Rates of Return to Education: Does the Conventional Pattern Prevail in Sub-Saharan Africa?](#)' *World Development* 24(1): 183-199.
- Benos, N. and Zotou, S. (2013) '[Education and Economic Growth A Meta-Regression Analysis](#)'. Personal RePEc Archive MPRA Paper 46143. Munich: MPRA.
- Béteille, T. (2009) '[Absenteeism, Transfers and Patronage: The Political Economy of Teacher Labor Markets in India](#)'. PhD Dissertation, Stanford, CA: Stanford University.
- Beuermann, D.W., Cristia, J.P., Cruz-Aguayo, Y., Cueto, S. and Malamud, O. (2013) '[Home Computers and Child Outcomes. Short-Term Impacts from a Randomized Experiment in Peru](#)'. Working Paper 18818. Cambridge, MA: NBER.
- Bils, M. and Klenow, P.J. (2000) '[Does Schooling Cause Growth?](#)' *American Economic Review* 90(5): 1160-1183.
- Birdsall, N. (1985) '[Public Inputs and Child Schooling in Brazil](#)'. *Journal of Development Economics* 18(1): 67-83.
- Bitler, M.P., Domina, T., Penner, E. and Hoynes, H. (2013) '[Distributional Effects of a School Voucher Program. Evidence from New York City](#)'. Working Paper 19271. Cambridge, MA: NBER.
- Blanden, J. (2005) '[International Evidence on Intergenerational Mobility](#)'. Washington, DC, and London: CEPR and LSE.
- Blundell, R., Dearden, L. and Sianesi, B. (2001) '[Estimating the Returns to Education. Models, Methods and Results](#)'. London: Centre for the Economics of Education. LSE.
- Bobonis, G.E.M. and Puri-Sharma, C. (2006) '[Anemia and School Participation](#)'. *Journal of Human Resources* 41: 692-721.
- Böhlmark, A. and Lindahl, M. (2012) '[Independent Schools and Long-Run Educational Outcomes. Evidence from Sweden's Large Scale Voucher Reform](#)'. Discussion Paper 6683. Stockholm: IZA.
- Bold, T., Kimenyi, M., Mwabu, G. and Sandefur, J. (2011) '[Does Abolishing Fees Reduce School Quality? Evidence from Kenya](#)'. Working Paper WPS/2011-04. Oxford: CSAE.
- Bold, T., Kimenyi, M., Mwabu, G., Ng'ang'a, A. and Sandefur, J. (2013) '[Scaling-up What Works, Experimental Evidence on External Validity in Kenyan Education](#)'. Working Paper WPS/2013-04. Oxford: CSAE.

- Breierova, L. and Duflo, E. (2004) '[The Impact of Education on Fertility and Child Mortality. Do Fathers Really Matter Less than Mothers?](#)' Working Paper 10513. Cambridge, MA: NBER.
- Breton, T.R. (2011) '[The Quality vs. the Quantity of Schooling: What Drives Economic Growth?](#)' *Economics of Education Review* 30: 765-773.
- Brückner, M. and Gradstein, M. (2013) 'Income and Schooling'. Discussion Paper 9365. Washington, DC: CEPR.
- Bruneforth, M. (2009) 'Differences in the Age Distribution of Primary Pupils Between Administrative and Household Data and the Impact on Monitoring of Enrolment Rates'. Montreal: UIS.
- Burde, D. and Linden, L.L. (2012) '[The Effect of Village-Based Schools. Evidence from a Randomized Controlled Trial in Afghanistan](#)'. Working Paper 18039. Cambridge, MA: NBER.
- Burgess, S., Davies, N. and Slater, H. (2009) '[Do Teachers Matter? Measuring Teacher Effectiveness in England](#)'. Working Paper 09/212. Bristol: CMPO.
- Burlando, A. (2012) '[The Impact of Malaria on Education. Evidence from Ethiopia](#)'. Portland, OR: University of Oregon.
- Buttenheim, A., Alderman, H. and Friedman, J. (2011) '[Impact Evaluation of School Feeding Programs in Lao PDR](#)'. Policy Research Working Paper 5518. Washington, DC: World Bank.
- Caldwell, J.C. (1979) 'Education as a Factor in Mortality Decline: An Examination of Nigerian Data'. *Population Studies* 33: 395-415.
- Card, D. (2001) '[Estimating the Return to Schooling: Progress on Some Persistent Econometric Problems](#)'. *Econometrica* 69(5): 1127-1160.
- Cardoso, E. and Souza, A. (2004) '[The Impact of Cash Transfers on Child Labor and School Attendance in Brazil](#)'. Working Paper 0407. Vanderbilt: Vanderbilt University, Department of Economics.
- Carneiro, P., Lokshin, M., Ridao-Cano, C. and Umapathi, N. (2011) '[Average and Marginal Returns to Upper Secondary Schooling in Indonesia](#)'. Policy Research Working Paper 5878. Washington, DC: World Bank.
- Carnoy, M., Luschei, T., Marshall, J.H., Naranjo, B. and Sorto, A. (2007) 'Improving Panama's and Costa Rica's Education Systems for the 21st Century Economy: A Comparative Study'. Stanford, CA: Stanford University School of Education.
- Case, A. and Deaton, A. (1999) '[School Inputs and Educational Outcomes in South Africa](#)'. *Quarterly Journal of Economics* 114(3): 1047-1084.
- Cerdan-Infantes, P. and Vermeersch, C. (2007) '[More Time Is Better. An Evaluation of the Full Time School Program in Uruguay](#)'. Policy Research Working Paper 4167. Washington, DC: World Bank.
- Chaudhury, N., Hammer, J., Kremer, M., Muralidharan, K. and Rogers, F.H. (2006) '[Missing in Action: Teacher and Health Worker Absence in Developing Countries](#)'. *Journal of Economic Perspectives* 20(1): 91-116.
- Chevalier, A., Harmon, C., Walker, I. and Zhu, Y. (2003) '[Does Education Raise Productivity, or Just Reflect It?](#)' Working Paper WP03/04. Dublin: UCD Centre for Economic Research.
- Chevalier, A., Harmon, C., O'Sullivan, V. and Walker, I. (2005) '[The Impact of Parental Income and Education on the Schooling of Their Children](#)'. Working Paper 05/05. London: Institute of Fiscal Studies.



- Chou, S., Liu, J., Grossman, M. and Joyce, T. (2010) '[Parental Education and Child Health: Evidence from a Natural Experiment in Taiwan](#)'. *American Economic Journal: Applied Economics* 2(1): 33-61.
- Clark, D. and Royer, H. (2010) '[The Effect of Education on Adult Health and Mortality: Evidence from Britain](#)'. Working Paper 16013. Cambridge, MA: NBER.
- Clotfelter, C.T., Ladd, H. and Vigdor, J. (2006) '[Teacher-Student Matching and the Assessment of Teacher Effectiveness](#)'. Working Paper 11936. Cambridge, MA: NBER.
- Cohen, D. and Soto, M. (2007) '[Growth and Human Capital. Good Data, Good Results](#)'. *Journal of Economic Growth* 12: 51-76.
- Colclough, C., Kingdon, G. and Patrinos, H.A. (2009) '[The Pattern of Returns to Education and Its Implications](#)'. RECOUP Policy Brief 4, April.
- Cortés, P. (2010) '[The Feminization of International Migration and its Effects on the Families Left Behind: Evidence from the Philippines](#)'. Boston, MA: Boston University.
- Cox Edwards, A. and Ureta, M. (2003) '[International Migration, Remittances and Schooling: Evidence from El Salvador](#)'. *Journal of Development Economics* 72(2): 429-461. López-Córdova
- Cristia, J., Ibarra, P., Cueto, S., Santiago, A. and Severin, E. (2012) '[Technology and Child Development: Evidence from the One Laptop per Child Program](#)'. Working Paper Series 304. Santiago: IADB.
- Cutler, D.M., Lange, F., Meara, E., Richards-Shubik, S. and Ruhm, C.J. (2011) '[Rising Educational Gradients in Mortality. The Role of Behavioral Risk Factors](#)'. *Journal of Health Economics* 30(6): 1174-1187.
- Dang, H.A. (2007) '[The Determinants and Impact of Private Tutoring Classes in Vietnam](#)'. *Economics of Education Review* 26(6): 684-699.
- Das, J., Dercon, S., Habyarimana, J. and Krishnan, P. (2007) '[Teacher Shocks and Student Learning: Evidence from Zambia](#)'. *Journal of Human Resources* 42(4): 820-862.
- Davies, J.B., Zhang, J. and Zeng, J. (2005) '[Intergenerational Mobility under Private vs. Public Education](#)'. *Scandinavian Journal of Economics* 107(3): 399-417.
- Day Ashley, L., Mcloughlin, C., Aslam, M., Engel, J, Wales, J., Rawal, S. Batley, R., Kingdon, G., Nicolai, S. and Rose, P. (2014) '[The Role and Impact of Private Schools in Developing Countries: A Rigorous Review of the Evidence](#)'. London: DFID.
- Dearden L., Machin, S. and Reed, H. (1997) '[Intergenerational Mobility in Britain](#)'. *Economic Journal* 107: 47-66.
- Dee, T.S. (2004) '[Are There Civic Returns to Education?](#)' *Journal of Public Economics* 88(9-10): 1697-1720.
- DeTray, D. (1988) 'Government Policy, Household Behavior, and the Distribution of Schooling: A Case Study of Malaysia, in T.P. Schultz (ed.) [Research in Population Economics](#), Vol. 6. Greenwich, CT: JAI Press.
- Devereux, P. and Fan, W. (2011) '[Earnings Returns to the British Education Expansion](#)'. *Economics of Education Review* 30(6): 1153-1166.
- DFID (Department for International Development) (2014) 'Learning Achievement, Engaging with Evidence, A Working Evidence Paper'. London: DFID.
- Di Maria, C. and Lazarova, E.A. (2012) '[Migration, Human Capital Formation, and Growth: An Empirical Investigation](#)'. *World Development* 40(5): 938-955.
- Dickson, M. and Harmon, C. (2011) '[Economic Returns to Education, What We Know, What We Don't Know, and Where We Are Going – Some Brief Pointers.](#)' *Economics of Education Review* 30(6): 1118-1122.

- Dickson, M.R. and Smith, S. (2011) '[What Determines the Return to Education: An Extra Year or a Hurdle Cleared?](#)' *Economics of Education Review* 30(6): 1167-1176.
- Duflo, E. (2001) '[Schooling and Labor Market Consequences of School Construction in Indonesia. Evidence from an Unusual Policy Experiment](#)'. *American Economic Review* 91(4): 795-813.
- Duflo, E. and Banerjee, A. (2011) *Poor Economics: A Radical Rethinking of the Way to Fight Global Poverty*. New York: Penguin.
- Duflo, E., Dupas, P. and Kremer, M. (2010) '[Peer Effects, Teacher Incentives, and the Impact of Tracking. Evidence from a Randomized Evaluation in Kenya](#)'. Cambridge, MA: Abdul Latif Jameel Poverty Action Lab (J-PAL).
- Duflo, E., Hanna, R. and Ryan, S. (2012) '[Incentives Work. Getting Teachers to Come to School](#)'. *American Economic Review* 102(4): 1241-1278.
- Duraisamy, P. (2002) '[Changes in Returns to Education in India, 1983-94: By Gender, Age-Cohort and Location](#)'. *Economics of Education Review* 21(6): 609-622.
- Dustmann, C. and Glitz, A. (2011) '[Migration and Education](#)', in E.A. Hanushek, S. Machin and L. Woessmann (eds) *Handbook of the Economics of Education, Vol. 4*.
- Dustmann, C. and Weiss, Y. (2007) '[Return Migration: Theory and Empirical Evidence from the UK](#)'. *British Journal of Industrial Relations* 45(2): 236-256.
- Dustmann, C., Fadlon, I. and Weiss, Y. (2010) '[Return Migration, Human Capital Accumulation and the Brain Drain](#)'. *Journal of Development Economics* 95(1): 58-67.
- Easterly, W. (2001) *The Elusive Quest for Growth: Economists' Adventures and Misadventures in the Tropics*. Boston, MA: MIT Press.
- Eberts, R.W. and Stone, J.A. (1987) 'Teachers' Unions and the Productivity of Public Schools'. *Economic Inquiry* 24: 631-644.
- Evans, D.K. and Ghosh, A. (2008) '[Prioritising Education Investments in Children in the Developing World](#)'. Working Paper. Santa Monica, CA: RAND Corporation.
- Evans, D., Kremer, M. and Ngatia, M. (2008) '[The Impact of Distributing School Uniforms on Children's Education in Kenya](#)'. Cambridge, MA: Abdul Latif Jameel Poverty Action Lab (J-PAL).
- Fairlie, R. and Robinson, J. (2012) '[Experimental Evidence on the Effects of Home Computers on Academic Achievement among Schoolchildren](#)'. Working Paper 19060. Cambridge, MA: NBER.
- Fasih, T., Kingdon, G., Patrinos, H.A., Sakellariou, C. and Soderbom, M. (2012) '[Heterogeneous Returns to Education in the Labor Market](#)'. Policy Research Working Paper 6170. Washington, DC: World Bank.
- Fasih, T., Patrinos, H.A. and Sakellariou, C. (2013) '[Functional Literacy, Heterogeneity and the Returns to Schooling. Multi-Country Evidence](#)'. Policy Research Working Paper 6697. Washington, DC: World Bank.
- Ferreira, F.H.G., Filmer, D. and Schady, N. (2009) '[Own and Sibling Effects of Conditional Cash Transfer Programs](#)'. Policy Research Working Paper 5001. Washington, DC: World Bank.
- Figlio, D.N. and Kenny, L. (2007) '[Individual Teacher Incentives and Student Performance](#)'. *Journal of Public Economics* 91(5-6): 901-914.
- Filmer, D. and Schady, N. (2009) '[Are There Diminishing Returns to Transfer Size in Conditional Cash Transfers?](#)' Policy Research Working Paper 4999. Washington, DC: World Bank.

- Fletcher, J.M. (2010) '[Social Interactions and Smoking: Evidence Using Multiple Student Cohorts, Instrumental Variables, and School Fixed Effects](#)'. *Health Economics* 19(4): 466-484.
- Fraser, B., Walberg, H.J., Welch, W.W. and Hattie, J.A. (1987) 'Syntheses of Educational Productivity Research'. *International Journal of Education Research* 11(2): 145-252.
- Fredriksen, B. (2009) 'Rationale, Issues, and Conditions for Sustaining the Abolition of School Fees', in World Bank (2009) [Abolishing School Fees in Africa. Lessons from Ethiopia, Ghana, Kenya, Malawi and Mozambique](#). Washington, DC: IBRD.
- Fuller, B. (1986) '[Raising School Quality in Developing Countries: What Investments Boost Learning?](#)' Discussion Paper 2. Washington, DC: World Bank.
- García, S., Fernández, C. and Weiss, C. (2012) '[Does Lengthening the School Day Reduce the Likelihood of Early School Dropout and Grade Repetition, Evidence from Colombia](#)'. Population Association of America Annual Meeting, San Francisco, CA, 1-3 May.
- Gaviria, A. and Raphael, S. (2001) 'School-Based Peer Effects and Juvenile Behavior'. *The Review of Economics and Statistics* 83(2): 257-268.
- Ghuman, S. and Lloyd, C. (2010) '[Teacher Absence as a Factor in Gender Inequalities in Access to Primary Schooling in Rural Pakistan](#)'. *Comparative Education Review* 54(4): 539-554.
- Glewwe, P. (1999) '[Why Does Mother's Schooling Raise Child Health in Developing Countries? Evidence from Morocco](#)'. *Journal of Human Resources* 34 (1): 124-159.
- Glewwe, P. and Kremer, M. (2006) 'Schools, Teachers, and Education Outcomes in Developing Countries', in E. Hanushek and F. Welch (eds) [Handbook of the Economics of Education Vol. 2](#).
- Glewwe, P. and Nauman, I. (1996) '[The Determinants of School Attainment in Sub-Saharan Africa: A Case Study of Ghana](#)'. *Journal of International Development* 8(3): 395-413.
- Glewwe, P., Kremer, M. and Moulin, S. (2009) '[Many Children Left Behind? Textbooks and Test Scores in Kenya](#)'. *American Economic Journal – Applied Economics* 1(1): 112-135.
- Glewwe, P., Nauman, I. and Kremer, M. (2010) '[Teacher Incentives](#)'. *American Economic Journal: Applied Economics* 2(3): 205-227.
- Glewwe, P.W., Hanushek, E.A., Humpage, S.D. and Ravina, R. (2011) '[School Resources and Educational Outcomes in Developing Countries A Review of the Literature from 1990 to 2010](#)'. Working Paper 17554. Cambridge, MA: NBER.
- Glied, S. and Lleras-Muney, A. (2008) '[Technological Innovation and Inequality in Health](#)'. *Demography* 45(3): 741-761.
- Godoya, R., Reyes-García, V., Seyfried, C., Huanca, T., Leonard, W.R., McDade, T., Tanner, S. and Vadez, V. (2007) '[Language Skills and Earnings. Evidence from a Pre-Industrial Economy in the Bolivian Amazon](#)'. *Economics of Education Review* 26: 349-360.
- Goyal, S. and Pandey, P. (2009) '[How Do Government and Private Schools Differ? Findings from Two Large Indian States](#)'. Washington, DC: World Bank.
- Grogger, J. (1998) '[Market Wages and Youth Crime](#)'. *Journal of Labor Economics* 16: 756-791.
- Grossman, M. (1972) '[On the Concept of Health Capital and the Demand for Health](#)'. *Journal of Political Economy* 80(2): 223-255.

- Grossman, M. (2006) '[Education and Nonmarket Outcomes](#)', in E. Hanushek and F. Welch (eds), *Handbook of the Economics of Education*, Vol. 1.
- Handa, S. (2002) '[Raising Primary School Enrolment in Developing Countries. The Relative Importance of Supply and Demand](#)'. *Journal of Development Economics* 69(1): 103-128.
- Hanna, R. and Linden, L. (2009) '[Measuring Discrimination in Education](#)'. Working Paper 15057. Cambridge, MA: NBER.
- Hanushek, E.A. (2003) '[The Failure of Input-Based Schooling Policies](#)'. *Economic Journal* 113(485): F64-F98.
- Hanushek, E.A. (2005) '[The Economics of School Quality](#)'. *German Economic Review* 6(3): 269-286.
- Hanushek, E.A. (2008) '[Incentives for Efficiency and Equity in the School System](#)'. *Perspektiven der Wirtschaftspolitik* 9, Special Issue: 5-27.
- Hanushek, E.A. (2010) '[Education Production Functions, Developed Country Evidence](#)', in P. Peterson, E. Baker and B. McGaw (eds) *International Encyclopaedia of Education 2*: 407-411.
- Hanushek, E.A. and Kimko, D.D. (2000) '[Schooling, Labor Force Quality, and the Growth of Nations](#)'. *American Economic Review* 90(5): 1184-1208.
- Hanushek, E. and Rivkin, S.G. (2006) 'Teacher Quality', in E. Hanushek and F. Welch (eds) *Handbook of the Economics of Education, Vol. 2*.
- Hanushek, E.A. and Woessmann, L. (2010) '[How Much Do Educational Outcomes Matter in OECD Countries?](#)' Working Paper 16515. Cambridge, MA: NBER.
- Hanushek, E.A. and Woessmann, L. (2011) 'Overview of the Symposium for Performance Pay for Teachers'. *Economics of Education Review* 30: 391-393.
- Hanushek, E.A. and Woessmann, L. (2012) '[Schooling, Educational Achievement, and the Latin American Growth Puzzle](#)'. *Journal of Development Economics* 99(2): 497-512.
- Hanushek, E., Kain, J., O'Brien, D. and Rivkin, S. (2005) '[The Market for Teacher Quality](#)'. Working Paper 11154. Cambridge, MA: NBER.
- Hanushek, E.A., Schwerdt, G., Wiederhold, S. and Woessmann, L. (2013) '[Returns to Skills around the World. Evidence from PIAAC](#)'. Paris: OECD EDU-WKP.
- Härmä, J. (2011) '[Study of Private Schools in Lagos. Abuja](#)'. Report, LG303. Abuja: Education Sector Support Programme in Nigeria, DFID.
- Heckman, J. and Hotz, V. (1986) 'An Investigation of the Labour Market Earnings of Panamanian Males: Evaluating the Sources of Inequality'. *Journal of Human Resources* 21: 507-542.
- Hoxby, C. (1996) '[How Teachers' Unions Affect Education Production](#)'. *Quarterly Journal of Economics* 111(4): 671-718.
- Hoxby, C. (2000) '[Does Competition among Public Schools Benefit Students and Tax Payers?](#)' *American Economic Review* 90: 1209-1238.
- Hsieh, C. and Urquiola, M. (2003) '[When Schools Compete, How Do They Compete? An Assessment of Chile's Nationwide School Voucher Program](#)'. New York: Columbia University. Mimeo.
- Hubbard, P. (2007) '[Putting the Power of Transparency in Context: Information's Role in Reducing Corruption in Uganda's Education Sector](#)'. Working Paper 136. Washington, DC: Center for Global Development.

IMF (International Monetary Fund), OECD (Organisation for Economic Co-operation and Development), UN and World Bank (2011) '[Supporting the Development of More Effective Tax Systems](#)'. Report to the G-20 Development Working Group.

IMF (International Monetary Fund) (2012) '[Factsheet: Debt Relief under the Heavily Indebted Poor Countries \(HIPC\) Initiative](#)'. Washington, DC: IMF.

Jensen, R.T. (2010a) 'The (Perceived) Returns to Education and the Demand for Schooling'. *Quarterly Journal of Economics* 125(2): 515-548.

Jensen, R.T. (2010b) 'Economic Opportunities and Gender Differences in Human Capital: Experimental Evidence from India'. Working Paper 16021. Cambridge, MA: NBER.

Kazianga, H., de Walque, D. and Alderman, H. (2009) '[Educational and Health Impacts of Two School Feeding Schemes. Evidence from a Randomized Trial in Rural Burkina Faso](#)'. Policy Research Working Paper 4976. Washington, DC: World Bank.

Kim, S. and Lee, J.-H. (2004) '[Private Tutoring and Demand for Education in South Korea](#)'. Milwaukee, WI: Department of Economics, University of Wisconsin. Mimeo.

Kingdon, G. (1998) '[Does the Labour Market Explain Lower Female Schooling in India?](#)' *Journal of Development Studies* 35(1): 39-65.

Kingdon, G. and Muzammil, M. (2008) '[The Political Economy of Education in India, Teacher Politics in Uttar Pradesh](#)'. Oxford: Oxford University Press.

Kingdon, G. and Muzammil, M. (2013) '[The School Governance Environment in Uttar Pradesh: Implications for Teacher Accountability and Effort](#)'. *Journal of Development Studies* 49(2): 251-269.

Kingdon, G. and Teal, F. (2010) '[Teacher Unions, Teacher Pay and Student Performance in India: A Pupil Fixed Effects Approach](#)'. *Journal of Development Economics* 91(2): 278-288.

Kingdon, G. and Unni, J. (2001) 'Education and Women's Labour Market Outcomes in India'. *Education Economics* 9(2): 173-195.

Kingdon, K., Aslam, M., Rawal, S. and Das, S. (2013) '[Are Contract Teachers and Para-Teachers a Cost-Effective Intervention to Address Teacher Shortage and Improve Learning Outcomes?](#)' London: EPPI-Centre, Social Science Research Unit, Institute of Education, University of London.

Kingdon, G., Little, A., Aslam, M., Rawal, S., Moe, T., Patrinos, H., Beteille, T. and Banerji, R. (2014) 'A Rigorous Review of the Political Economy of Education Systems in Developing Countries'. Final Report commissioned by DFID.

Kremer, M. (2012) '[Improving Education in the Developing World: Evidence from Randomized Evaluations](#)'. Cambridge, MA: Harvard University.

Kremer, M., Miguel, E. and Thornton, R. (2004) '[Incentives to Learn](#)'. Working Paper 10971. Cambridge, MA: NBER.

Kremer, M., Chaudhury, N., Rogers, F.H., Muralidharan, K. and Hammer, J. (2005) '[Teacher Absence in India: A Snapshot](#)'. *Journal of the European Economic Association* 3(2-3): 658-667.

Krueger, A. (1999) '[Experimental Estimates of Education Production Functions](#)'. *Quarterly Journal of Economics* 114: 497-532.

Krueger, A. (2003) '[Economic Considerations and Class Size](#)'. *Economic Journal* 113: 34-63.

Krueger, A. and Rouse, C. (2004) '[Putting Computerized Instruction to the Test: A Randomized Evaluation of a "Scientifically-Based" Reading Program](#)'. *Economics of Education Review* XXIII: 323-338.

- Kuecken, M. and Valfort, M. (2013) '[When Do Textbooks Matter for Achievement? Evidence from African Primary Schools](#)'. *Economic Letters* 119: 311-315.
- Krutikova, S. (2010) '[Who Gets to Stay in School? Long-run Impact of Income Shocks on Schooling in Rural Tanzania](#)'. Working Paper 2010-36. Oxford: CSAE.
- Lam, D. and Schoeni, R.F. (1993) '[Effects of Family Background on Earnings and Returns to Schooling: Evidence from Brazil](#)'. *Journal of Political Economy* 101(4): 710-40.
- Lange, F. (2011) '[The Role of Education in Complex Health Decisions: Evidence from Cancer Screening](#)'. *Journal of Health Economics* 30(1): 43-54.
- Lassibille, G. and Tan, J.P. (2005) '[The Returns to Education in Rwanda](#)'. *Journal of African Economies* 14(1): 92-116.
- Lavy, V. (1996) '[School Supply Constraints and Children's Educational Outcomes in Rural Ghana](#)'. *Journal of Development Economics* 51(2): 291-314.
- Lavy, V. (2002) '[Evaluating the Effects of Teachers' Performance Incentives on Pupil Achievement](#)'. *Journal of Political Economy* 110(6): 1286-1317.
- Lemieux, T. (2003) '[The "Mincer Equation" Thirty years after Schooling, Experience and Earnings](#)'. Center for Labor Economics Working Paper 62. Berkeley, CA: , University of California, Berkeley.
- Leuven, E., Lindahl, M., Oosterbeek, H. and Webbink, D. (2004) '[The Effect of Extra Funding for Disadvantaged Pupils on Achievement](#)'. Discussion Paper 1122. Pretoria: IZA.
- Lewis, W.C. and Chakraborty, K. (1996) '[Scale Economies in Public Education](#)'. *Journal of Regional Analysis & Policy* 26(1): 23-35.
- Lindeboom, M., Llena-Nozal, A. and van der Klaauw, B. (2009) '[Parental Education and Child Health: Evidence from a Schooling Reform](#)'. *Journal of Health Economics* 28(1): 109-131.
- Lipset, S. (1959) '[Some Social Requisites for Democracy: Economic Development and Political Legitimacy](#)'. *American Political Science Review* 53(1): 69-105.
- Lleras-Muney, A. (2005) '[The Relationship between Education and Adult Mortality in the United States](#)'. *The Review of Economic Studies* 72(1): 189-221.
- Lochner, L. (2011) '[Non-Production Benefits of Education. Crime, Health, and Good Citizenship](#)'. Working Paper 16722. Cambridge, MA: NBER.
- Lopez-Acevedo, G. (2004) '[Professional Development and Incentives for Teacher Performance in Schools in Mexico](#)'. Policy Research Working Paper 3236. Washington, DC: World Bank.
- López-Córdova, J.E. (2005) '[Globalization, Migration, and Development: The Role of Mexican Migrant Remittances](#)'. *Economía* 6(1): 217-256.
- Lucas, A.M. (2010) '[Malaria Eradication and Educational Attainment: Evidence from Paraguay and Sri Lanka](#)'. *American Economic Journal: Applied Economics* 2(2): 46-71.
- Lucas, R.E. (1988) '[On the Mechanics of Economic Development](#)'. *Journal of Monetary Economics* 22(1): 3-42.
- Machin, S. and Vignoles, A. (2005) '[What's the Good of Education?](#)' CentrePiece Spring. London: Centre for the Economics of Education, LSE.
- Machin, S., McNally, S. and Silva, O. (2006) '[New Technology in Schools: Is There a Payoff?](#)' Working Paper. London: LSE.
- Machin, S., Marie, O. and Vujic, S. (2011) '[The Crime Reducing Effect of Education](#)'. *The Economic Journal* 121(552): 463-484.

- Malamud, O. and Pop-Eleches, C. (2011) '[Home Computer Use and the Development of Human Capital](#)'. *Quarterly Journal of Economics* 126: 987-1027.
- Maluccio, J. and Flores, R. (2005) '[Impact Evaluation of a Conditional Cash Transfer Program: The Nicaraguan Red de Proteccion Social](#)'. Washington, DC: IFPRI.
- Mazumder, B. (2008) '[Does Education Improve Health? A Reexamination of the Evidence from Compulsory Schooling Laws](#)'. *Economic Perspectives* 33: 2-16.
- McEwan, P.J. (2013a) '[The Impact of Chile's School Feeding Program on Education Outcomes](#)'. *Economics of Education Review* 32(1): 122-139.
- McEwan, P.J. (2013b) '[Improving Learning in Primary Schools of Developing Countries: A Meta-Analysis of Randomised Experiments](#)'. Cambridge, MA: Centre for Education Innovations.
- McLoughlin, C. (2013) '[Low-Cost Private Schools: Evidence, Approaches and Emerging Issues](#)'. EPS-PEAKS Topic Guide. London: DFID.
- Meara, E.R., Richards, S. and Cutler, D. (2008) '[The Gap Gets Bigger: Changes In Mortality And Life Expectancy, By Education, 1981-2000](#)'. *Health Affairs* 27(2): 350-360.
- Menezes-Filho, N. and Pazello, E. (2007) '[Do Teachers' Wages Matter for Proficiency? Evidence from a Funding Reform in Brazil](#)'. *Economics of Education Review* 26(6): 660-672.
- Meng, X. and Ryan, J. (2003) '[Evaluating the Food for Education Program in Bangladesh](#)'. Canberra: Australia South Asia Research Centre, Australian National University.
- Miguel, T. and Kremer, M. (2004) '[Worms. Identifying Impacts on Education and Health in the Presence of Treatment Externalities](#)'. *Econometrica* 72(1): 159-217.
- Milligan, K., Moretti, E. and Oreopoulos, P. (2004) '[Does Education Improve Citizenship? Evidence from the United States and the United Kingdom](#)'. *Journal of Public Economics* 88(9-10): 1667-1695.
- Mincer, J.A. (1974) 'Schooling, Experience, and Earnings'. Cambridge, MA: NBER.
- Moe, T.M. (2001) 'Private Vouchers: Politics and Evidence', in M.C. Wang and H.J. Walberg (eds) [School Choice or Best Systems: What Improves Education?](#) Mahwah, NJ: Lawrence Erlbaum.
- Moe, T.M. (2006) '[Political Control and the Power of the Agent](#)'. *Journal of Law, Economics and Organization* 22(1): 1-29.
- Moleni, C.M. and Ndalama, L. (2004) 'Teacher Absence and Attrition in Primary Schools in Malawi: A Case Study of Four Districts'. Zomba: Centre for Educational Research and Training, Malawi Institute of Education.
- Moll, P. (1996) '[The Collapse of Primary Schooling Returns in South Africa, 1960-90](#)'. *Oxford Bulletin of Economics and Statistics* 58(1): 185-209.
- Mulkeen, A. (2010) '[Teachers in Anglophone Africa: Issues in Teacher Supply, Training, and Management](#)'. Washington, DC: World Bank.
- Mulligan, C. (1999) '[Galton versus the Human Capital Approach to Inheritance](#)'. *Journal of Political Economy* 107: 184-224.
- Muralidharan, K. and Kremer, M. (2009) 'Public and Private Schools in Rural India', in R. Chakrabarti and P. Peterson (eds) [School Choice International: Explaining Public-Private Partnerships](#). Cambridge, MA: MIT.
- Muralidharan, K. and Sundararaman, V. (2009) '[Teacher Performance Pay: Experimental Evidence from India](#)'. Working Paper 15323. Cambridge, MA: NBER.

- Muralidharan, K. and Sundararaman, V. (2011) '[Contract Teachers – Experimental Evidence from India](#)'. *Journal of Political Economy* 119(1): 39-77.
- Murphy, K.M., Shleifer, A. and Vishny, R.W. (1991) '[The Allocation of Talent, Implications for Growth](#)'. *Quarterly Journal of Economics* 106(2): 503-530.
- Nelson, R.R. and Phelps, E. (1966) 'Investment in Humans, Technology Diffusion, and Economic Growth'. *American Economic Review* 56(2): 69-75.
- Nguyen, T. (2008) '[Information, Role Models and Perceived Returns to Education: Experimental Evidence from Madagascar](#)'. Working Paper. Cambridge, MA: MIT.
- Norton, E.C., Lindrooth, R.C. and Ennett, S. (1998) '[Controlling for the Endogeneity of Peer Substance Use on Adolescent Alcohol and Tobacco Use](#)'. *Health Economics* 7: 439-453.
- Novelli, M., Higgins, S., Valiente, O. and Ugur, M. (2013) 'The Political Economy of Education Systems in Conflict-Affected Contexts: A Rigorous Literature Review'. London: DFID.
- Oster, E. and Thornton, R. (2011) '[Menstruation, Sanitary Products, and School Attendance. Evidence from a Randomized Evaluation](#)'. *American Economic Journal: Applied Economics* 3: 91-100.
- PAISA Report (2012) '[Do Schools Get Their Money? PAISA 2012](#)'. Delhi: Accountability Initiative and ASER.
- Pal, S. (2010) '[Public Infrastructure, Location of Private Schools and Primary School Attainment in an Emerging Economy](#)'. *Economics of Education Review* 29(5): 783-794.
- Patrinos, H.A., Ridao, C. and Sakellariou, C. (2009) '[A Note on Schooling and Wage Inequality in the Public and Private Sector](#)'. *Empirical Economics* 37(2): 383-392.
- PISA (Programme for International Student Assessment) (2012) [Results in Focus](#). Paris: OECD.
- Powell, L.M., Tauras, J.A. and Ross, H. (2005) '[The Importance of Peer Effects, Cigarette Prices and Tobacco Control Policies for Youth Smoking Behavior](#)'. *Journal of Health Economics* 24(5): 950-968.
- Pratichi India Trust (2002) [The Pratichi Education Report II: Primary Education in West Bengal, Changes and Challenges](#). Delhi: Pratichi India Trust.
- Pritchett, L. (1997) '[Divergence, Big Time](#)'. *Journal of Economic Perspectives* 11(3): 3-17.
- Pritchett, L. (2001) '[Where Has All the Education Gone?](#)' *World Bank Economic Review* 15(3): 367-391.
- Pritchett, L. (2014) '[The Risks to Education Systems from Design Mismatch and Global Isomorphism](#)'. Working Paper 2014/039. Helsinki: UNU WIDER.
- Pritchett, L. and Filmer, D. (1997) '[What Do Education Production Functions Really Show: A Positive Theory of Education Expenditures](#)'. Washington, DC: World Bank.
- Psacharopoulos, G. (1985) '[Returns to Education: A Further International Update and Implications](#)'. *Journal of Human Resources* 20(4): 583-604.
- Psacharopoulos, G. (1994) '[Returns to Investment in Education: A Global Update](#)'. *World Development* 22(9): 1325-1343.
- Psacharopoulos, G. and Patrinos, H.A. (2004a) '[Returns to Investment in Education: A Further Update](#)'. *Education Economics* 12(2): 111-134.
- Psacharopoulos, G. and Patrinos, H.A. (2004b) 'Human Capital and Rates of Return', in G. Johnes and J. Johnes (eds) [International Handbook on the Economics of Education](#). Cheltenham: Edward Elgar Publishing.



- Ramgaraju, B., Tooley, J. and Dixon, P. (2012) [\*The Private School Revolution in Bihar: Findings from a Survey in Patna Urban\*](#). New Delhi and Newcastle: India Institute and EG West Centre, Newcastle University.
- Reinikka, R. and Svensson, J. (2002) '[Assessing Frontline Service Delivery](#)'. Washington, DC: Development Research Group, World Bank.
- REPOA (Research on Poverty Alleviation) (2004) '[Tanzania Public Expenditure Tracking Study. Study of Financial and Non-Financial PEDP Flows from Central Government to Schools in 2002 and 2003](#)'. Dar es Salaam: REPOA and the Ministry of Finance.
- Reynolds, A.J., Temple, J.A., Robertson, D.L. and Mann, E.A. (2001) 'Long-Term Effects of an Early Childhood Intervention on Education Achievement and Juvenile Arrest: A 15-Year Follow-up of Low-Income Children in Public Schools'. *Journal of the American Medical Association* 285: 2339-2346.
- Rivkin, S., Hanushek, E. and Kain, J. (2005) '[Teachers, Schools and Academic Achievement](#)'. *Econometrica* 73(2): 417-458.
- Robinson, J. (1953) '[The Production Function and the Theory of Capital](#)'. *Review of Economic Studies* 21(2): 81-106.
- Rockoff, J. (2004) '[The Impact of Individual Teachers on Student Achievement: Evidence from Panel Data](#)'. *American Economic Review* 94(2): 247-252.
- Romer, P.M. (1986) '[Increasing Returns and Long-Run Growth](#)'. *Journal of Political Economy* 94: 1002-1037.
- Romer, P.M. (1994) '[The Origins of Endogenous Growth](#)'. *Journal of Economic Perspectives* 8(1): 3-22.
- Rosenzweig, M. (1995) '[Why Are There Returns to Schooling?](#)' *American Economic Review* 85(2): 153-158.
- Rouse, C. (1998) '[Private School Vouchers and Student Achievement: An Evaluation of the Milwaukee Parental Choice Program](#)'. *Quarterly Journal of Economics* 113(2): 553-602.
- Rouse, C. (1999) '[Further Estimates of the Economic Return to Schooling from a New Sample of Twins](#)'. *Economics of Education Review* 18(2): 149-157.
- Sala-i-Martin, X. (1997) '[I Just Ran Four Million Regressions](#)'. Working Paper 6252. Cambridge, MA: NBER.
- Santibañez, L. and Rabling, B. (2006) '[Muscle, Timing and Priorities: Teacher Unions and Education Quality in Mexico](#)'. Washington, DC: World Bank.
- Schady, N. and Filmer, D. (2006) '[Getting Girls into School: Evidence from a Scholarship Program in Cambodia](#)'. Working Paper 3910. Washington, DC: World Bank.
- Schultz, T.P. (2004a) '[School Subsidies for the Poor: Evaluating the Mexican Progresa Poverty Program](#)'. *Journal of Development Economics* 74: 199-250.
- Schultz, T.P. (2004b) '[Evidence of Returns to Schooling in Africa from Household Surveys: Monitoring and Restructuring the Market for Education](#)'. *Journal of African Economies* 13(2): 95-148.
- Sharma, R. (2009) 'The Internal Dynamic', in R. Sharma and V. Ramachandran (eds) [\*The Elementary Education System in India: Exploring Institutional Structures, Processes and Dynamics\*](#). New Delhi: Routledge.
- Sianesi, B. and van Reenen, J. (2003) '[The Returns to Education: A Review of the Empirical Macroeconomic Literature](#)'. *Journal of Economic Surveys* 17(2): 157-200.
- Singh, R. and Sarkar, S. (2012) [\*Teaching Quality Counts: How Student Outcomes Relate to Quality of Teaching in Private and Public Schools in India\*](#). Oxford: Young Lives.

- Soares de Baldini Rocha, M. and Ponczek, V. (2011) '[The Effects of Adult Literacy on Earnings and Employment](#)'. *Economics of Education Review* 30(4): 755-764.
- Söderbom, M., Teal, F., Wambugu, A. and Kahyarara, G. (2006) '[The Dynamics of Returns to Education in Kenyan and Tanzanian Manufacturing](#)'. *Oxford Bulletin of Economics and Statistics* 68(3): 261-288.
- Solon, G. (1999) '[Intergenerational Mobility in the Labor Market](#)', in O. Ashenfelter and D. Card (eds) *Handbook of Labor Economics, Vol 3A*.
- Sparrow, R. (2007) '[Protecting Education for the Poor in Times of Crisis: An Evaluation of a Scholarship Programme in Indonesia](#)'. *Oxford Bulletin of Economics and Statistics* 69: 99-122.
- Spence, M. (1973) '[Job Market Signaling](#)'. *Quarterly Journal of Economics* 87(3): 355-374.
- Spohr, C. (2003) '[Formal Schooling and Workforce Participation in a Rapidly Developing Economy: Evidence from "Compulsory" Junior High School in Taiwan](#)'. *Journal of Development Economics* 70: 291-327.
- Sprietsma, M. and Waltenberg, F. (2005) 'The Impact of Teacher's Wages on Student's Performance in the Presence of Heterogeneity and Endogeneity – Evidence from Brazil'. Working Paper 2005008. Louvain: Université Catholique de Louvain, Département des Sciences Economiques.
- Stern, J.M.B. and Heyneman, S.P. (2013) '[Low-Fee Private Schooling: The Case of Kenya](#)', in P. Srivastava (ed.) *Low-Fee Private Schooling: Aggravating Equity or Mitigating Disadvantage?* Oxford: Symposium Books.
- Stiglitz, J. and Weiss, A. (1981) '[Credit Rationing in Markets with Imperfect Information](#)'. *American Economic Review* 71(3): 393-410.
- Strauss, J. and Thomas, D. (1995) 'Human Resources: Household Decisions and Markets', in Behrman, J. and Srinivasan, T (eds) *Handbook of Development Economics, Vol. 3*. Amsterdam: North Holland.
- Sundet, G. (2007) 'Public Expenditure Tracking Studies: Lessons from Tanzania'. U4 Brief 14. Bergen: Chr. Michelsen Institute.
- Sundet, G. (2008) '[Following the Money: Do Expenditure Tracking Surveys Matter?](#)' Anti-Corruption Resource Centre, U4, Issue 2008:8.
- Suryadarma, D., Suryahadi, A., Sumarto, S. and Rogers, F.H. (2006) *Improving Student Performance in Public Primary Schools in Developing Countries: Evidence from Indonesia*. Washington, DC: World Bank.
- Tarabini, A. and Jacovkis, J. (2012) '[The Poverty Reduction Strategy Papers, An Analysis of a Hegemonic Link between Education and Poverty](#)'. *International Journal of Educational Development* 32(4): 507-516.
- Taubman, P. (1976) '[The Determinants of Earnings: Genetics, Family, and Other Environments; A Study of White Male Twins](#)'. *American Economic Review* 66(5): 858-870.
- Temple, J. (2001) '[Growth Effects of Education and Social Capital in the OECD Countries](#)'. *OECD Economic Studies* 33: 2001/II.
- Todd, P. and Wolpin, K. (2006) '[Assessing the Impact of a School Subsidy Program in Mexico: Using a Social Experiment to Validate a Dynamic Behavioral Model of Child Schooling and Fertility](#)'. *American Economic Review* 96: 1384-1417.
- Tomasevski, K. (2006) [The State of the Right to Education Worldwide, Free or Fee. 2006 Global Report](#). UN Special Rapporteur on the Right to Education. Copenhagen: UN.

- Tsou, M., Liu, J. and Hammitt, J. (2011) '[The Intergenerational Transmission of Education: Evidence from Taiwanese Adoptions](#)'. Toulouse: LERNA, University of Toulouse.
- UNESCO (UN Educational, Scientific and Cultural Organization) (2010) '[Education For All \(EFA\) Global Monitoring Report 2010](#)'. Paris: UNESCO.
- UNESCO (UN Educational, Scientific and Cultural Organization) (2011) '[Financing Education in Sub-Saharan Africa – Meeting the Challenges of Expansion, Equity and Quality](#)'. Paris: UNESCO Institute of Statistics.
- UNESCO (UN Educational, Scientific and Cultural Organization) (2012a) '[Education For All \(EFA\) Global Monitoring Report 2012](#)'. Paris: UNESCO.
- UNESCO (UN Educational, Scientific and Cultural Organization) (2012b) '[Untangling Aid in National Education Budgets](#)'. Technical Note prepared for the Education for All Global Monitoring Report 2012.
- UNESCO (UN Educational, Scientific and Cultural Organization) (2014) '[Education For All \(EFA\) Global Monitoring Report 2013/2014](#)'. Paris: UNESCO.
- Uwezo Uganda (2011) '[Are Our Children Learning? Annual Learning Assessment Report](#)'. Kampala: Uwezo Uganda.
- Van de Walle, N. (2001) '[African Economies and the Politics of Permanent Crisis: 1979-1999](#)'. Cambridge: Cambridge University Press.
- Vasudeva-Dutta, P. (2004) '[The Structure of Wages in India, 1983-1999](#)'. PRUS Working Paper 25. Brighton: University of Sussex.
- Vermeersch, C. and Kremer, M. (2005) '[School Meals, Educational Achievement, and School Competition: Evidence from a Randomized Evaluation](#)'. Working Paper 3523. Washington, DC: World Bank.
- Wagle, S. and Shah, S. (2003) '[Case Study 5 – Uganda: Participatory Approaches in Budgeting and Public Expenditure Management](#)'. Social Development Note 74. Washington, DC: World Bank.
- WHO (World Health Organization) (2013) '[10 Facts on Malaria](#)'. Geneva: WHO.
- Woessmann, L. (2003) '[Schooling Resources, Educational Institutions and Student Performance: The International Evidence](#)'. *Oxford Bulletin of Economics and Statistics* 65(2): 117-170.
- Woessmann, L. (2011) '[Cross-Country Evidence on Teacher Performance Pay](#)'. *Economics of Education Review* 30(3): 404-418.
- World Bank (2011) '[Do Conditional Cash Transfers Lead to Medium-Term Impacts? Evidence from a Female School Stipend Program in Pakistan](#)'. Washington, DC: Independent Evaluation Group, World Bank.
- World Bank (2013) '[Africa's Pulse: An Analysis of Issues Shaping Africa's Economic Future](#)'. Washington, DC: World Bank.

## Annex A: Additional data

This annex provides some additional data to illustrate points made within the Education Economics Topic Guide.

### Conditional convergence

**Figure A1: Annual growth of GDP per worker, 1960-2000, and log of GDP per worker, 1960 – no unconditional convergence**

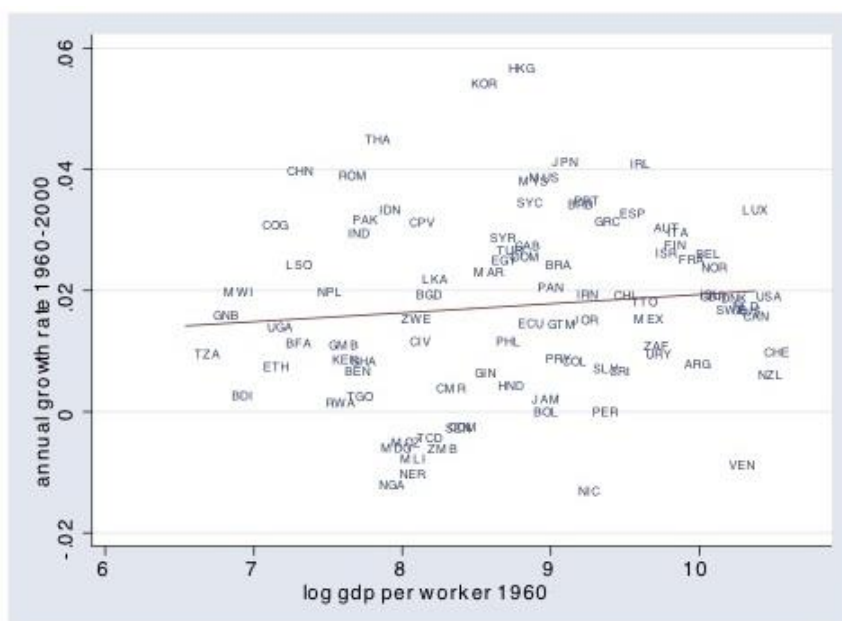

Source: Acemoglu (2007).

### GDP and schooling relationship

**Figure A2: Average growth of GDP per capita, 1960-2000, and average years of schooling, 1960-2000**

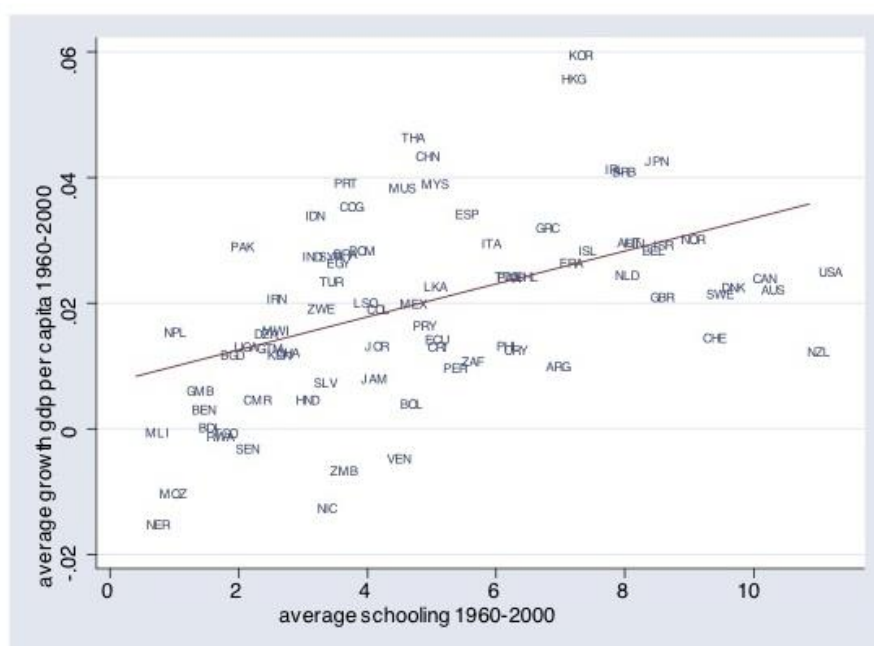

Source: Acemoglu (2007).

### Inequalities in educational performance

**Figure A3: Children aged 6-9 years who have never been to school, by type of impairment, for selected countries, 2005-2007 (%)**

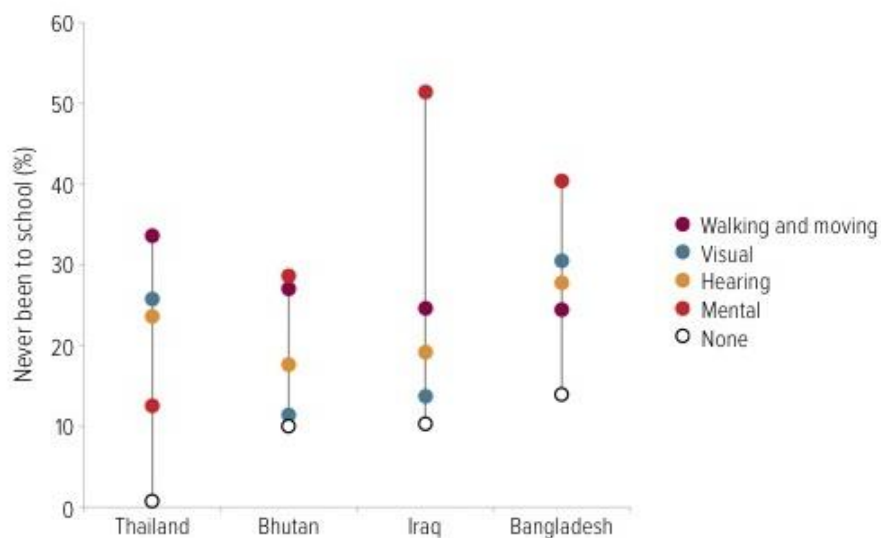

Source: UNESCO (2012a).

**Figure A4: Population aged 17-22 with fewer than two years of education, by wealth quintile for selected countries**



Source: UNESCO (2012a).

## Educational spending by households

**Table A1: Average household expenditure on education per child in Ghana (in local currency), 2007**

		TUITION FEES FOR SCHOOL OR DUES FOR PARENTS' ASSOCIATION	ROOM AND BOARD	TEXTBOOKS AND SCHOOL SUPPLIES	UNIFORMS AND SPORTS CLOTHING	TRANSPORTATION TO AND FROM SCHOOL	TUTORING, SPECIAL CLASSES	TOTAL
Public school	Pre-primary	3.6*	24.9	1.1	3.7	1.0	0.8	35.1
	Primary	4.1*	28.3	4.2	5.3	1.2	2.4	45.5
	Secondary – 1 <sup>st</sup> cycle	10.5*	45.0	9.5	7.4	4.4	8.8	85.6
	Secondary – 2 <sup>nd</sup> cycle	128.4	104.8	37.4	12.8	27.6	27.2	338.2
	Vocational/technical	85.6	93.7	23.7	11.3	15.5	10.5	240.3
	Teacher training	133.5	95.3	57.0	15.7	14.7	6.7	322.8
	University	433.1	334.3	159.7	7.1	71.8	5.4	1,011.4
	Post-secondary technical education	196.6	218.6	129.4	7.8	44.2	22.8	619.4
Private school	Pre-primary	48.3	54.5	5.5	8.7	15.4	4.0	136.4
	Primary	63.1	66.6	16.0	10.7	16.3	16.2	188.8
	Secondary – 1 <sup>st</sup> cycle	94.6	86.1	26.8	12.6	19.0	29.5	268.5
	Secondary – 2 <sup>nd</sup> cycle	238.8	105.2	41.0	14.8	25.1	23.9	448.7
	Vocational/technical	211.6	100.4	68.6	11.7	57.2	1.7	451.1
	Higher education	605.7	411.1	194.1	8.1	138.7	0.0	1,357.8

Source: UNICEF (2011).

## Teachers remuneration across countries

**Table A2: Average remuneration of primary and secondary teachers, 2009 or most recent year (% of GDP per capita)**

	PRIMARY EDUCATION	LOWER SECONDARY EDUCATION	UPPER SECONDARY EDUCATION
Angola (2003)	1.5	...	...
Benin (2006)	3.6	6.0	8.2
Burkina Faso (2006)	5.3	8.8	9.6
Burundi (2007)	7.6	8.4	12.2
Cameroon (2007)	3.2	5.2	5.5
Cape Verde (2009)	2.5	3.0	3.2
Central African Republic (2007)	3.3	6.9	7.1
Chad (2003)	5.4	8.8	9.8
Congo (2007)	0.9	2.0	2.5
Côte d'Ivoire (2007)	4.9	8.8	9.4
Democratic Republic of the Congo (2005)	3.9	2.4	2.4
Eritrea (2003)	7.7	...	...
Gambia (2003)	3.7	...	...
Ghana (2007)	4.7	4.7	4.8
Guinea (2005)	1.7	2.9	2.9
Guinea-Bissau (2006)	4.4	6.6	6.6
Kenya (2004)	5.3	7.6	7.6
Lesotho (2004)	5.0	10.4	10.4
Liberia (2008)	3.0	3.1	3.3
Madagascar (2006)	2.9	5.1	8.1
Malawi (2008)	6.3	11.6	11.6
Mali (2008)	4.2	5.6	6.6
Mozambique (2003)	4.0	...	...
Niger (2008)	6.6	7.4	8.6
Nigeria (2003)	4.9	...	...
Rwanda (2008)	2.6	6.4	7.3
Sao Tome and Principe (2006)	2.3	...	...
Senegal (2004)	4.7	5.5	6.6
Seychelles (2003)	1.7	...	...
Sierra Leone (2004)	4.2	5.9	5.9
Sudan (2003)	2.2	...	...
Togo (2007)	6.1	8.9	11.6
Uganda (2007)	4.7	...	...
Zambia (2003)	2.7	...	...
Zimbabwe (2003)	6.1	...	...
Average (35 countries)	4.1	6.3	7.2
Minimum	0.9	2.0	2.4
Maximum	7.7	11.6	12.2

Source: UNICEF (2011).

### Pupil-teacher ratios in Sub-Saharan Africa

**Figure A5: SSA pupil-teacher ratios in primary education, 2009 or nearest year**

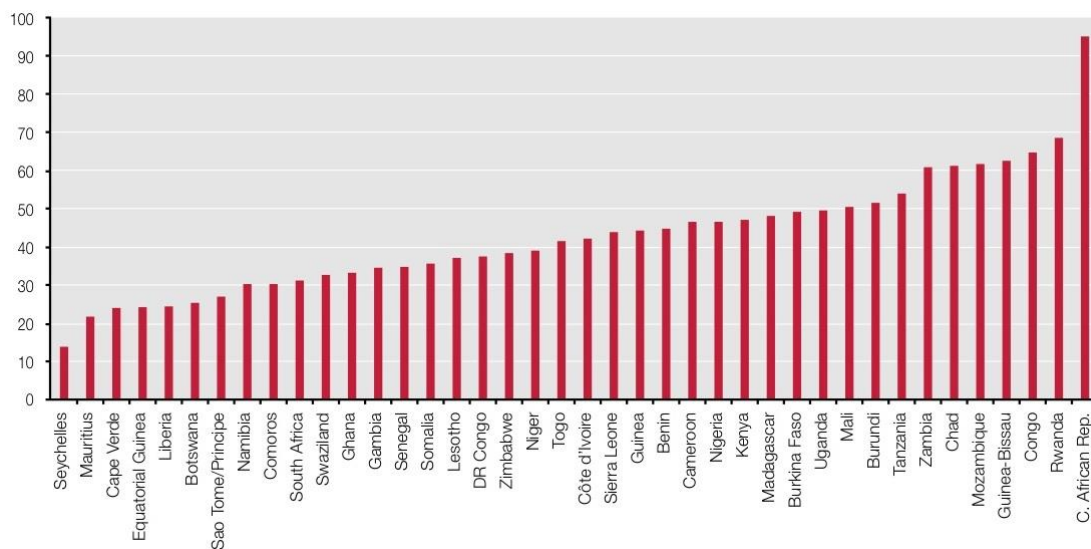

Source: UNICEF (2011).

### Spending on education

**Figure A6: Public expenditure, low- and middle-income countries, 1999 and 2011 (% of GDP)**

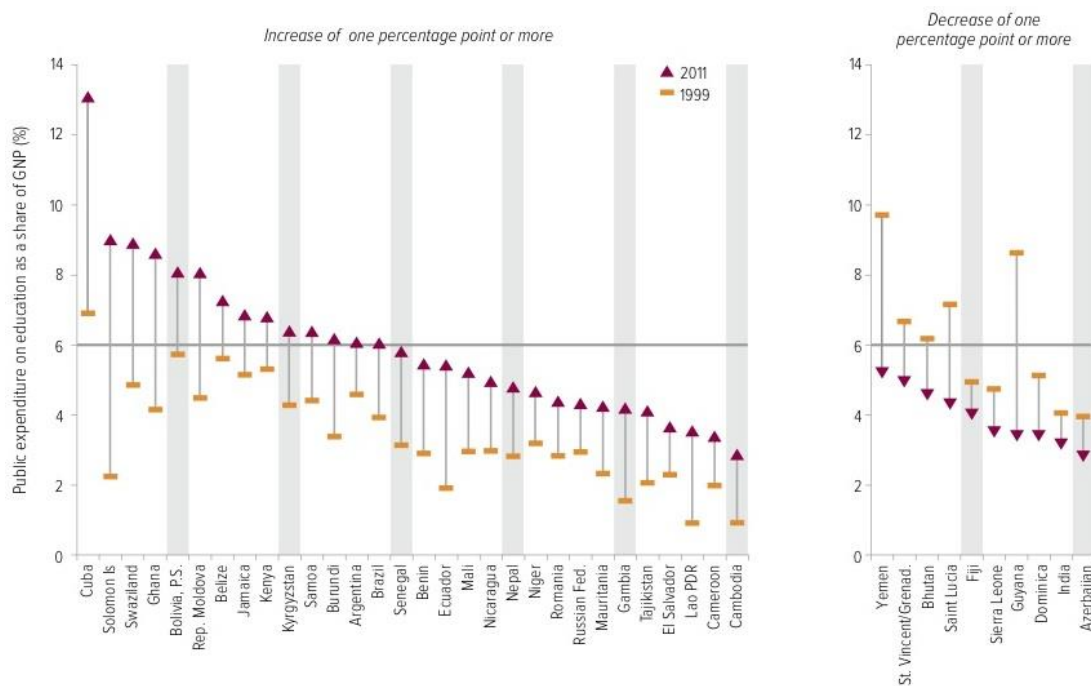

Source: UNICEF (2011).



**Figure A7: Primary education expenditure per pupil, 2009 or most recent year (% of GDP per capita)**

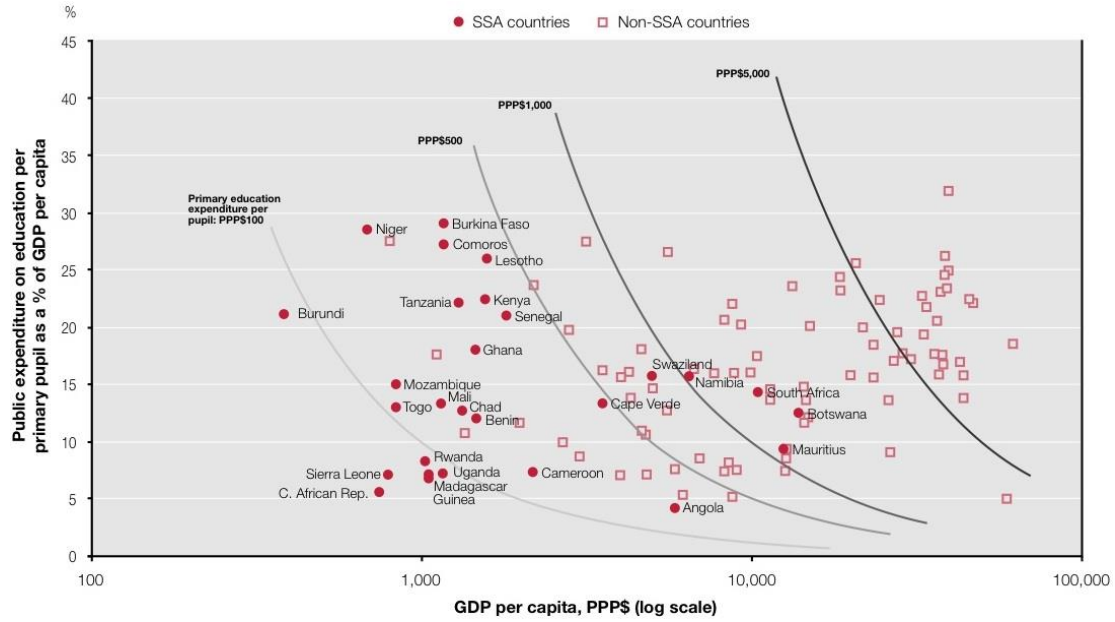

Source: UNICEF (2011).

## Annex B: Methodological appendix

This annex provides a brief note on some of the methodological approaches used by academic papers discussed in this topic guide. These are approaches that seek to show more robustly the levels of causation between two variables, usually the presence of a policy or intervention and the educational outcomes of interest, while controlling for key *missing or omitted variables*.

### Randomised evaluation/randomised control trial

A randomised controlled trial (RCT), a term used interchangeably with *randomised evaluation*, is a method that has become a gold standard for making policy inferences in developing country contexts, particularly given the shortage of long-term panel datasets to use other approaches. RCTs have been borrowed from medical science and applied extensively in economics and policymaking, led by the pioneering group of economists at the Abdul Latif Jameel Poverty Action Lab and Innovations for Poverty Action (IPA), who have used them to measure the effectiveness of poverty, health and education interventions in the developing world. The distinguishing feature of an RCT is that study subjects are put in an intervention group or control group after assessment of eligibility and recruitment, but before the intervention begins. Random allocation provides a good means of ensuring the two groups are similar in key respects, and therefore any measurable change should be attributable to the project or policy intervention. RCTs require good sample sizes to ensure statistical significance, meaning they can be a costly way to evaluate interventions.

### Instrumental variables

The instrumental variable (IV) methodology identifies variables that are correlated with the variable of interest, such as schooling, but not correlated with unobserved variables, such as ability. In the context of estimating the effect of greater educational attainment on health, for example, an instrument is valid if it would correlate with higher or lower levels of schooling but would not correlate with other factors that directly affect health outcomes, such as smoking. Researchers often exploit social and natural experiments for an instrument, such as institutional variations or restrictions on the minimum school-leaving age.<sup>91</sup> Experiment-based IV approaches have significant data demands, which are often therefore difficult in developing country contexts. This usually involves large sets of long-term panel data across a cohort of individuals – for example the 1970 British Cohort Survey, which follows more than 17,000 individuals.

### Regression discontinuity

A method associated with IV is regression discontinuity (RD). By comparing observations lying closely on either side of a policy threshold, it is possible to estimate the *local average treatment effect* in environments in which randomisation is unfeasible. This means comparing changes either side of a major policy change such as regulations on the school-leaving age, which impact on one year group as against the previous year group (Lochner, 2011). Here, the outcomes for the group that has had to stay at school longer compared with the group that has had less time in school can provide an estimate of the returns to education while controlling for other factors. This requires a solid legal change as well as sufficient panel data on outcomes, and is also therefore generally feasible only in developed country contexts.

### Fixed effects methods, including twins studies

An alternative to an IV or RD technique is to use repeated observations on the same individual over time or observations from different individuals within the same

---

<sup>91</sup> Card (1999) provides a summary of these approaches from the early 1990s.

family/household. This method is premised on the notion that a good part of unobserved differences (such as in innate ability) is common among family members. Thus, using at least two individuals within the family and calculating a *fixed effect* eliminates the common, typically unobserved, components (such as ability), presuming them to be identical among family members. Such estimates can be based on, for example, samples of twins, siblings or father–son or mother–daughter pairs, and will use a ‘fixed effect’ or first differencing approach. By introducing sub-samples of households with at least two individuals, the fixed effects method therefore effectively controls for all household variables that are ‘common’ across all these individuals within a given household. Pure family fixed effects methods are more plausible for samples of twins within the same household and may not be very convincing among other groupings (such as other siblings within the family or father–son or mother–daughter pairs).<sup>92</sup>

---

<sup>92</sup> See Card (1999) for a good summary of such studies.